

FRONTY DO MEBLI

Bel Visa[®]

by viyar



SPIS TREŚCI

Historia Bel Viso	2
Produkcja Bel Viso	4
Zalety Bel Viso	5
Fronty fornirowane	6
Fronty lakierowane	14
Fronty foliowane	58
Fronty laminowane HPL	88
Fenix	90
Arpa	96
Fronty Bel Viso Glass	102
Fronty akrylowe	114
Crystal	116
Kontakt	122

Bel Viso[®]

BEL VISO

HISTORIA

Co to jest Bel Viso? Są to wysokiej jakości fronty do każdego wnętrza. To pragnienie, aby każdy pokój był stylowy, przytulny i pełen miłości.

Od czego to wszystko się zaczęło? Firma VIYAR od 2002 roku dostarcza komponenty i materiały do mebli. Długo wybieraliśmy fronty, które by nam odpowiadały według wszystkich kryteriów: idealny stosunek jakości do ceny, estetyka, indywidualne rozwiązania i orientacja na klienta. Dlatego w 2014 roku zdecydowaliśmy, że stworzymy własną markę, która zaspokoi wszystkie te potrzeby.

«Widzieliśmy radość i podziw ludzi, którzy po raz pierwszy widzą swój nowy dom. Miejsce pełne piękna i miłości.»

Dlatego zdecydowaliśmy: we produce happiness»

Produkty Bel Viso to wysokiej jakości rozwiązania dla każdego. Wszystkie próbki materiałów są dostępne w salonach VIYAR, gdzie można je dotknąć, zobaczyć powierzchnię, porównać i wybrać zgodnie z własnymi potrzebami.

Wiosną 2021 roku VIYAR otworzył własną fabrykę do produkcji frontów Bel Viso w Wasilkowie.





HISTORIA ROZWOJU MARKI



BEL VISO W CYFRACH



Całkowita powierzchnia fabryki w Wasilkowie – **10 000 m²**.



Bel Viso oferuje **10 rodzajów frontów** i **ponad 3000 odmian dekorów**.



Liczba pracowników fabryki – **400 specjalistów (350 – produkcja, 50 – administracja)**.



Fabryka Bel Viso posiada **ponad 100 sztuk profesjonalnego sprzętu**.



Od momentu powstania marki firma VIYAR wyprodukowała **około 1 mln m² frontów**.



Moce fabryczne stanowią **60 000 m² różnych typów frontów miesięcznie**.

Bel Viso[®]

BEL VISO

PRODUKCJA

Miesięcznie wykonujemy około 25 000 m² frontów. Produkcja własna umożliwia pełną kontrolę nad wszystkimi etapami produkcji – od zakupu surowców po pakowanie gotowych produktów.

Produkcja frontów meblowych



Materiały najlepszych marek

- MDF Egger
- Włoskie farby i lakiery Sayerlack i Votteler
- Fenix / ARPA
- Rehau
- Profil aluminiowy Cortizo
- Folia włoskiej i niemieckiej produkcji
- Fornir naturalny oraz fornir modyfikowany włoskiej marki ALPI



Profesjonalne wyposażenie

- Cięcie CNC Homag / Biesse
- Maszyny do wiercenia VNH
- Narzędzia diamentowe do obróbki mechanicznej
- Zrobotyzowany kompleks Fanuc do nakładania kleju
- Linia nakładająca powłoki lub farbę Cefla i inne

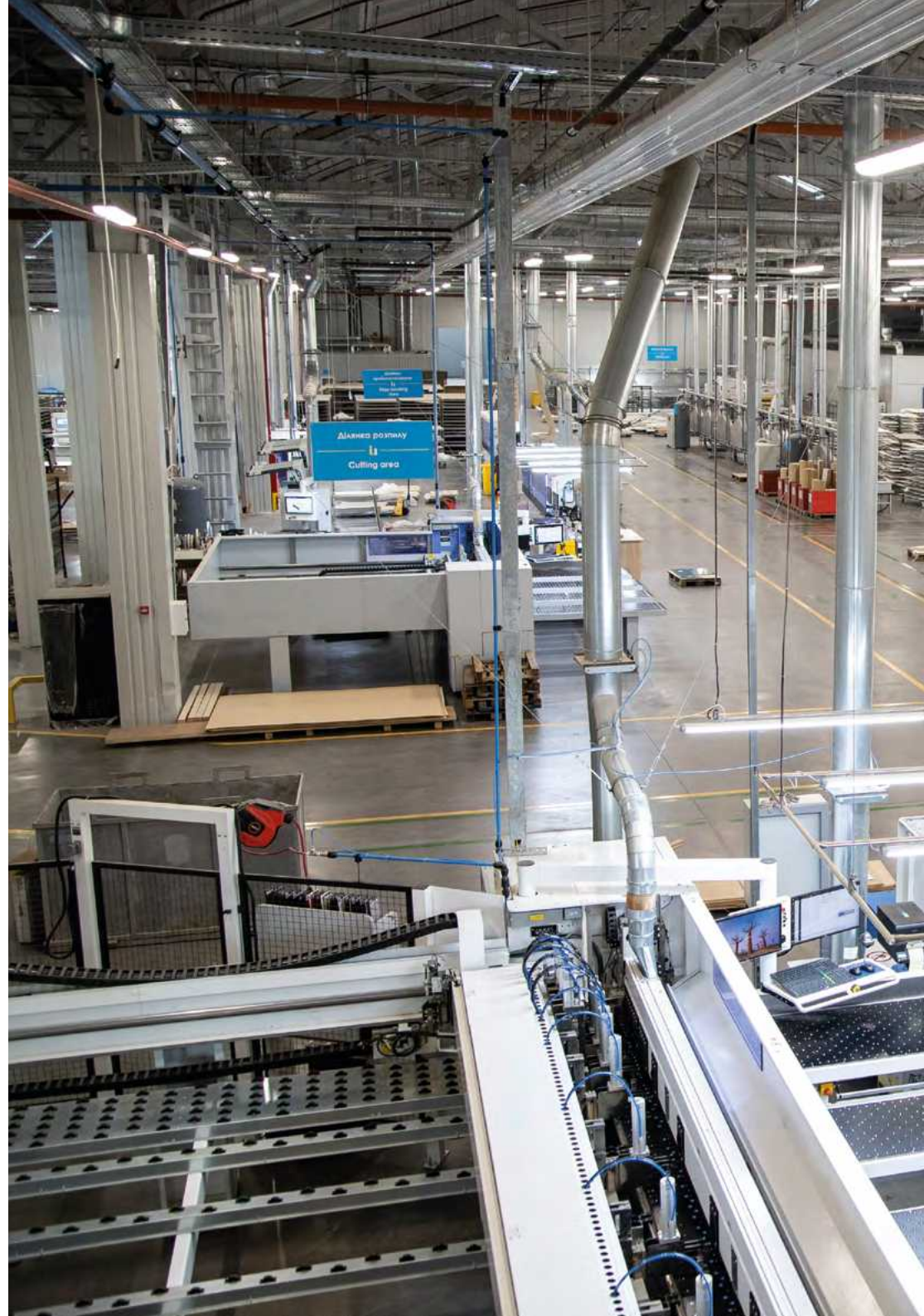



BEL VISO KORZYŚCI

- **Różne rodzaje powłok frontów:** matowe i błyszczące, jednokolorowe dekory i wzory, imitacje drewna, kamienia i innych materiałów.
- **Indywidualne podejście do każdego zamówienia.** Jesteśmy zawsze gotowi do realizacji niestandardowych rozwiązań i realizacji najbardziej kreatywnych pomysłów.
- **Obsługa klienta.** Bel Viso ma największe salony z frontami na Ukrainie i oferuje dogodne warunki do zamówień online: wybór wizualizacji na stronie VIYAR, projektowanie usług produkcyjnych w programie projektowym ViyarPro.
- **Dbłość o szczegóły.** Oferujemy gotowe zestawy uchwytów frezowanych i wpuszczanych we fronty.
- **Gwarancja 10 lat.** Wykorzystanie najlepszych materiałów i kontrola jakości na każdym etapie produkcji to nasze główne zasady działania.
- **Wysokiej jakości opakowanie,** które chroni fronty przed uszkodzeniami mechanicznymi podczas transportu.
- **Przyjazne produkty dla środowiska.** W produkcji używamy certyfikowanych materiałów, które są bezpieczne dla ludzi i środowiska.

Bel Viso

FRONTY FORNIROWANE

DOTKNIJ UNIKALNYCH WZORÓW NATURY

Fronty fornirowane Bel Viso pokryte są cienką warstwą okleiny naturalnej lub modyfikowanej (grubość 0,5 mm) na bazie MDF. Główne zalety to naturalna struktura i przyjemne w dotyku drewno. Obrzeża frontów również wykonane są z forniru.

Używamy dwóch fornirów:

- **Fornir naturalny** to skrawek drewna, który w pełni zachowuje swoją naturalną strukturę. Producent – «Euroszpon», Ukraina.
- **Fornir modyfikowany** wykonany jest zgodnie z technologią fine-line, która umożliwia stworzenie idealnej struktury i odcienia. Producent – ALPI, Włochy.

Fornir musi być pokryty warstwą lakieru, który gwarantuje ochronę przed wilgocią, barwnikami, promieniowaniem UV, a także umożliwia nadanie drewnu dowolnego odcienia. Rodzaje powłok: farby (katalogi RAL i NCS), bejce, lakiery matowe i półmatowe Sayerlack. Fornir modyfikowany pokryty jest tylko lakierami. Asortyment frontów fornirowanych obejmuje ponad 80 dekorów.

Bel Viso[®]





USŁUGI DODATKOWE

Dwustronna powłoka 

LKM (powłoka lakierniczo-bejcowana) 

EKO (materiał naturalny) 

Klejenie cięcia pod 45° 

Zachowanie tekstury drewna 

Lakierowanie próbki 



FRONTY FORNIROWANE

MATERIAŁY UŻYTE DO WIZUALIZACJI:

- Frezowanie: Nero 100
- Front: Lamella Dąb, MDF lakierowany matowy NCS S 1000-N
- Blat ARPA 0001 CLIFF 40 mm /art. 147631
 - Uchwyt Marella CL 24316.35 nikiel polerowany | czarny matowy /art. 69018

Bel Visa 

FREZOWANIE **NERO 100**

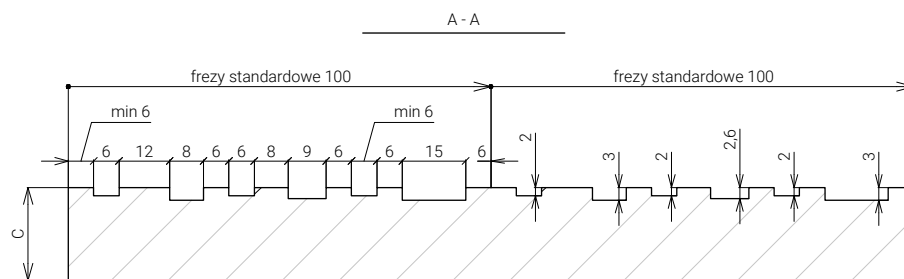

FREZOWANIE **EMMI 32**

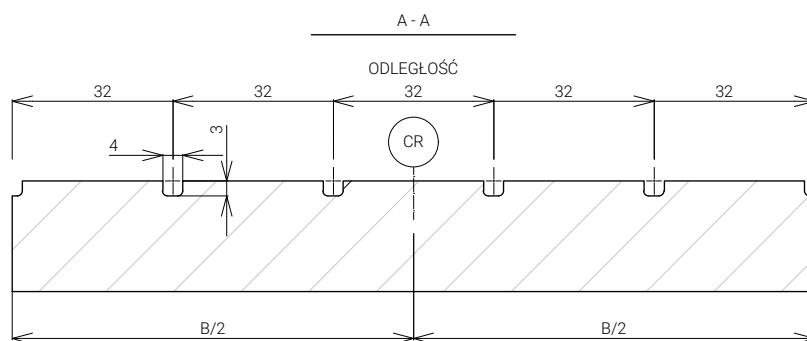

FREZOWANIE **WAVE 17**

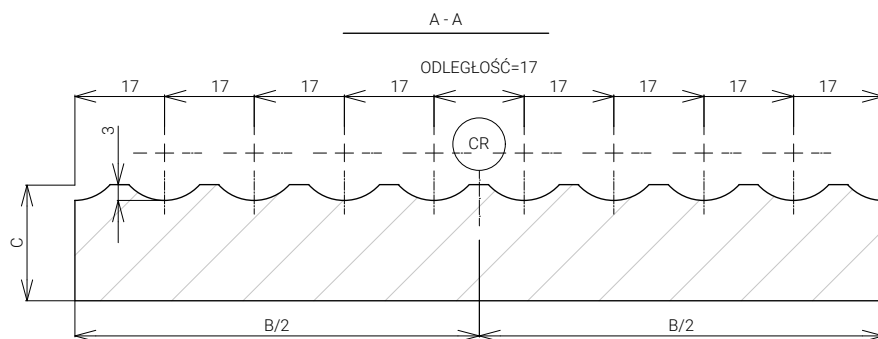



FRONTY FORNIROWANE

MATERIAŁY UŻYTE DO WIZUALIZACJI:

- Kolor: Dąb Naturalny Rustykalny
- Uchwyt Ferro Fiori M 0030.256, czarny /art. 146949
- Blat ARPA 3329 MIKA odporny na wilgoć /art. 146849

Bel **Viso**[®]



Fornir Dąb Klasyczny
Prostosłoiasty



Fornir Orzech Amerykański
Flader



Fornir Drzewo ambrowe
ALPI



Fornir Dąb Biały
18.50 ALPI



Fornir Lauro Preto
ALPI



Fornir Dąb dymiono-szary
10.65 ALPI





FRONTY FORNIROWANE



Fornir Dąb Europejski
Rough Cut 3D
ALPI



Orzech XILO
Flader 10.11
ALPI



Fornir Sucupira
ALPI



Fornir Wood Contur Dąb
Klasyczny Flader



Fornir Orzech Amerykański
Postarzały ALPI



Fornir Dąb Deskowy
12.96 ALPI



Fornir Orzech Amerykański
Falisty 12.19
ALPI



Fornir Dąb szary
XILO 18.23
ALPI



Fornir Orzech
włoski 10.95
ALPI



Fornir Dąb Dymiony
12.85 ALPI



Fornir Orzech szlachetny
ALPI



Fornir Palisander
2P 874/00/3 ALPI



FRONTY LAKIEROWANE

NIEOGRANICZONY WYBÓR

Fronty lakierowane Bel Viso to możliwość wyboru dowolnych kolorów i nie ograniczania się. Ponad 2500 kolorów z usługą lakierowania próbki (opcje z katalogów – RAL, WCP, NCS), różne powłoki, frezowanie, elementy dekoracyjne, frezowane uchwyty. Aby nadać im wyrafinowany antyczny wygląd, możesz zastosować 7 kolorów patyny. Lakierowane fronty są praktyczne, odporne na wilgoć i wysokie temperatury.

Płyta MDF pochodzi od austriackiego producenta Egger, pokryta włoskimi farbami Sayerlack. Używamy również lakierów akrylowych, które nie blakną z czasem. Produkcja frontów lakierowanych Bel Viso jest w pełni zautomatyzowana, dzięki czemu pojawienie się wad jest ograniczone do minimum.

Bel Viso[®]





USŁUGI DODATKOWE

Frezowany uchwyt 

Witryna (frezowanie na wylot) 

Dwustronna powłoka 

Patyna 

Lakierowanie próbki 

Zestaw do renowacji 

Ekspresowa produkcja gładkich frontów 

Frezowanie Indywidualne 

FRONTY

LAKIEROWANE ZE SZTUKATERIĄ



MATERIAŁY UŻYTE W WIZUALIZACJI:

- Kolor: RAL 9003 Panel ścienny
- Frezowanie: Model 1
- Uchwyt Marella M 15232.128 nikiel polerowany /art. 83723
- Uchwyt Marella M 24232.30 nikiel polerowany /art. 83725
- Blat Kwarc Caesarstone 5141 Frosty Carrina 20 mm

Bel Visa[®]

FREZOWANIE MODEL 1

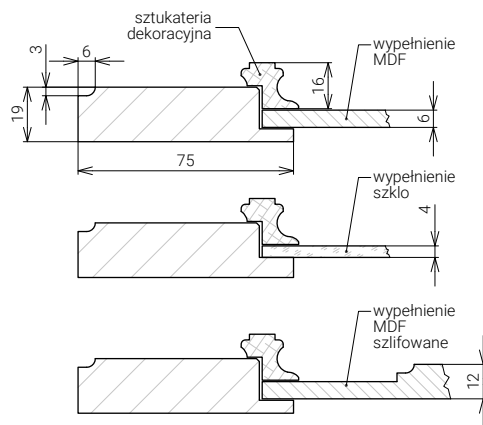

FREZOWANIE MODEL 2

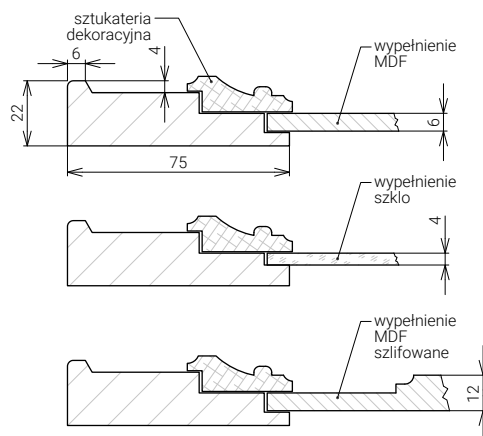

FREZOWANIE MODEL 3

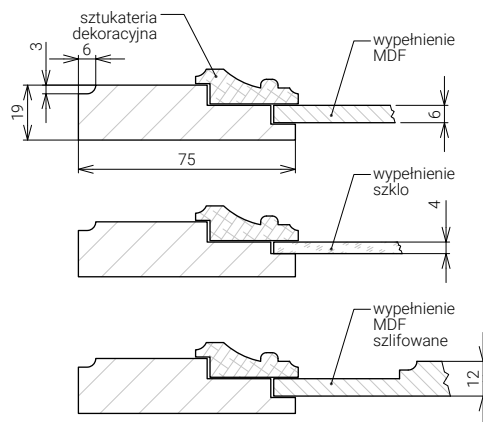

FRONTY LAKIEROWANE

Kolekcja «Variety of lines»

MATERIAŁY UŻYTE W WIZUALIZACJI:

- Kolor: VMA0307310
- Frezowanie: Nevis 19
- Blat: Spiek ceramiczny Inalco Azalai Negro natural 12 mm
- Panel ścienny: Spiek ceramiczny Inalco Azalai Negro natural 4 mm



Bel **Viso**[®]

FREZOWANIE **EMMI 32**

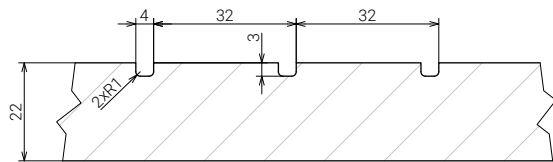

FREZOWANIE **KOS 21**

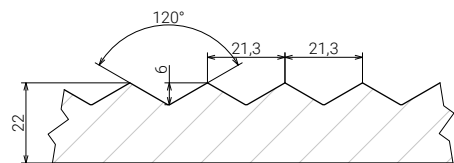

FREZOWANIE **NEVIS 19**

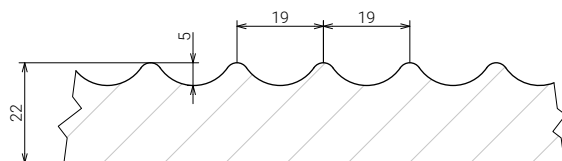

FREZOWANIE **SUNSET 15**

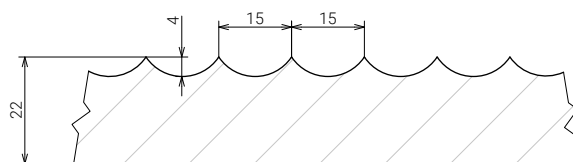

FREZOWANIE **FANCY 24**

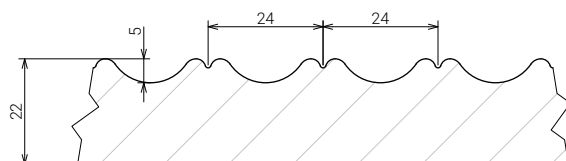

FRONTY LAKIEROWANE

Kolekcja «Variety of lines»

MATERIAŁY UŻYTE W WIZUALIZACJI:

- Kolor: RAL 9016
- Frezowanie: Liberty114
- Uchwyt relingowy RE 1006/320 (DR 10/320 G5) nikiel /art. 80804
- Uchwyt relingowy RE 1006/160 (DR 10/160 G5) nikiel /art. 80800
- Blat: Fornir Dąb Klasyczny Flader 38 mm
- Panel ścienny: Spiek ceramiczny Inalco Iseo Gris abujardado 4 mm



Bel **Viso**[®]

FREZOWANIE **ASTER 130**

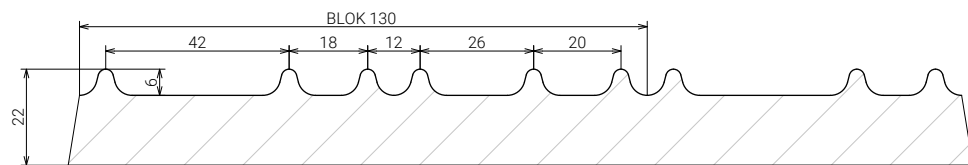

FREZOWANIE **NEVIS 24**

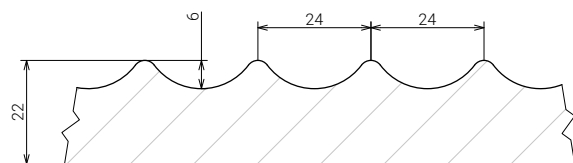

FREZOWANIE **SUNSET 20**

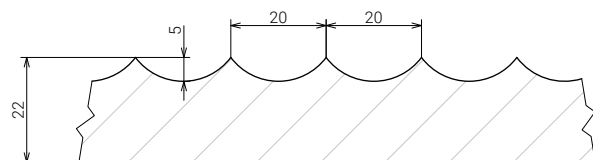

FREZOWANIE **FANCY 29**

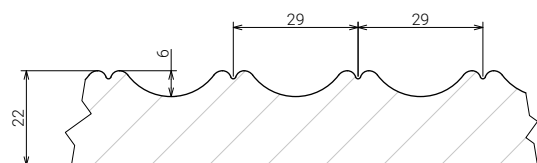

FREZOWANIE **NEVIS 28**

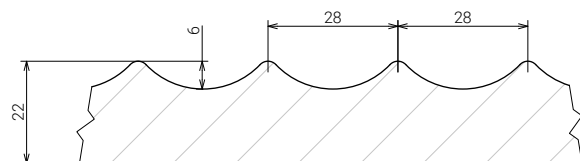



FRONTY LAKIEROWANE

Kolekcja «Variety of lines»

MATERIAŁY UŻYTE W WIZUALIZACJI:

- Kolor: NCS 1515-R20B
- Frezowanie: Airy 74
- Blat: Arkusz akrylowy Getacore GC 4410 Concrete Riva

Bel Viso[®]

FREZOWANIE **SUNSET 24**

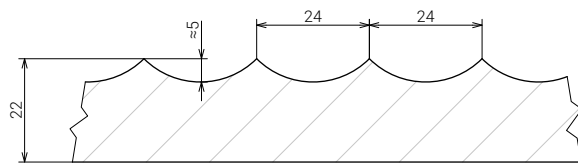

FREZOWANIE **FANCY 33**

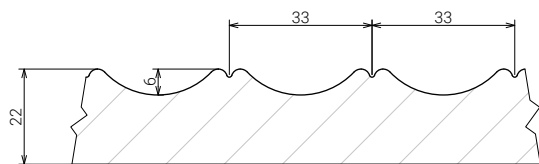

FREZOWANIE **SUNSET 64**

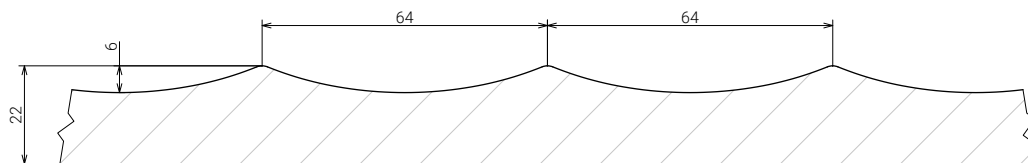

FREZOWANIE **FANCY 69**

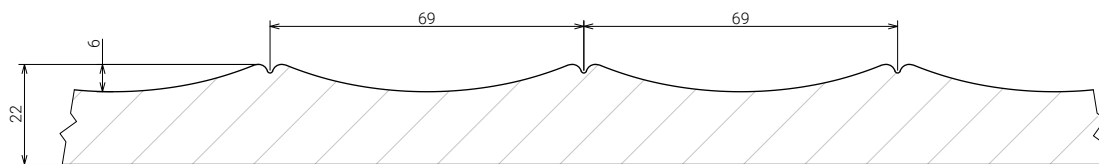

FREZOWANIE **AIRY 74**

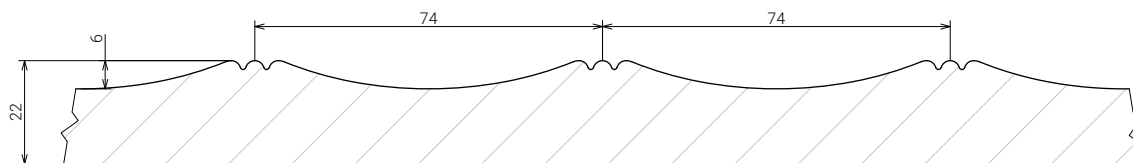

FRONTY LAKIEROWANE

Kolekcja «Variety of lines»

MATERIAŁY UŻYTE W WIZUALIZACJI:

- Kolor: NCS 1005-Y50R
- Frezowanie: Flores 55
- Blat: Kamień akrylowy Grandex Adventure A-418 Oak Wood 12 mm
- Panel ścienny: Spiek ceramiczny NEOLITH ClasStone Calacatta 01 R silk 6 mm

Bel **Viso**[®]



FRONTY LAKIEROWANE

Kolekcja «Variety of lines»

MATERIAŁY UŻYTE W WIZUALIZACJI:

- Kolor: NCS 1010-Y60R
- Frezowanie: Liberty 114
- Uchwyt Cosma M 12951.192 stal /art. 21819
- Blat: Kamień akrylowy Getacore GC 2388 Miracle Beach 10 mm
- Panel ścienny: Spiek ceramiczny Inalco Petra Crema abujardado 4 mm

Bel **Viso**[®]

FREZOWANIE CAVE 12

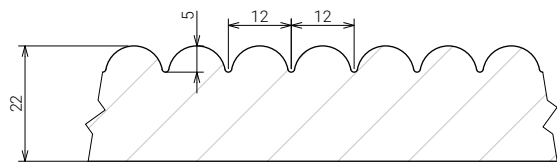

FREZOWANIE CAVE 14

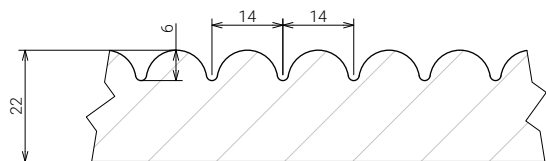

FREZOWANIE CAVE 17

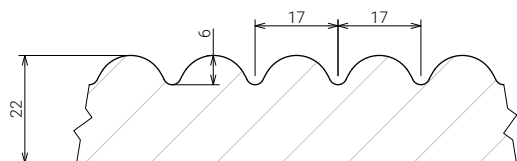

FREZOWANIE CAVE 20

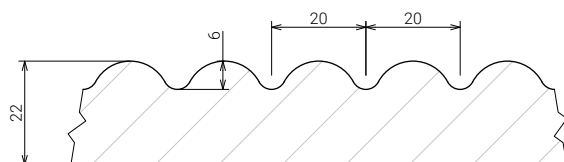

FREZOWANIE CAVE 28,5

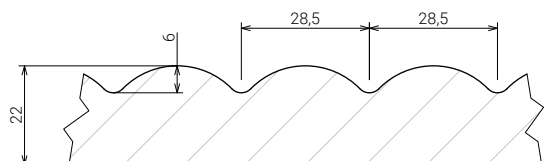



FRONTY LAKIEROWANE

MATERIAŁY UŻYTE W WIZUALIZACJI:

- Kolor: NCS S 4005Y20R
- Frezowanie: Alba
- Uchwyt Marella M 15194.160 grafit /art. 69687
- Uchwyt Marella M 15194.320 grafit /art. 69690
- Blat Kronospan K218 GG Andromeda Czarny 38 mm /art. 152899
- Skinali (na szkle brylant 6 mm) /art. 49756

Bel  *Viso*[®]

FREZOWANIE ALBA



RAL 9003



RAL 9001



RAL 9016



RAL 7036



RAL 9010



WCP 115

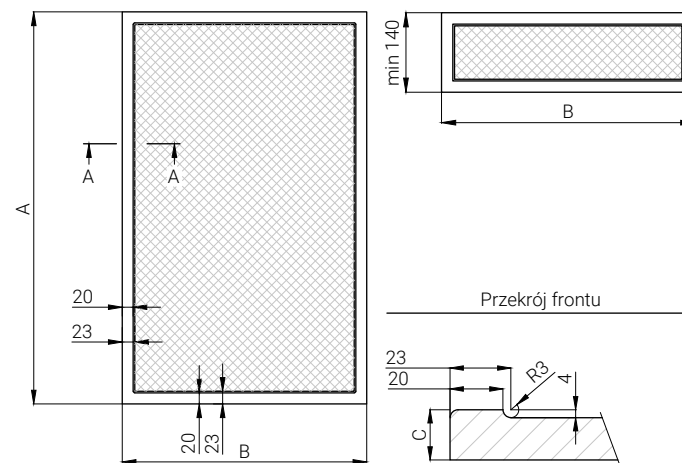



FRONTY LAKIEROWANE

MATERIAŁY UŻYTE W WIZUALIZACJI:

- Kolor: RAL 7043 transport szary B
- Frezowanie: Geometria
- Uchwyt 224-160 czarny /art. 91303
- Blat EGGER F117 / ST76 / R3-1U Kamień Ventura czarny 38 mm /art. 147896
- Panel ścienny: MDF Fenix NTM 0751 Jaipur / Arpa 0759 10 mm /art. 62123

Bel Viso[®]

FREZOWANIE GEOMETRIA



RAL 9002



RAL 7045



RAL 1013



RAL 7024



RAL 1015



RAL 7004

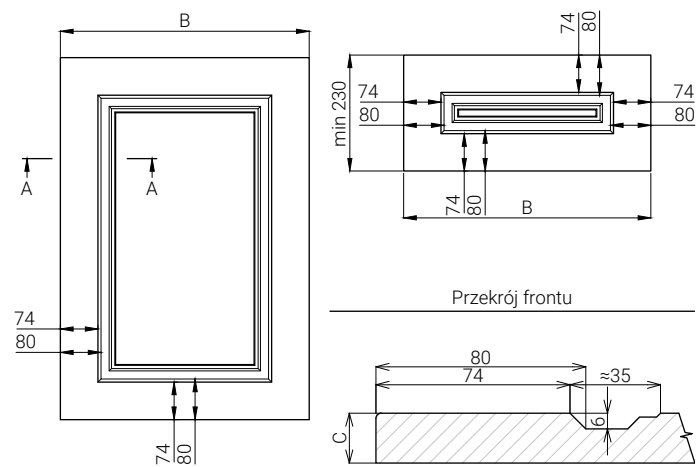

FRONTY LAKIEROWANE

MATERIAŁY UŻYTE W WIZUALIZACJI:

- Kolor: WCP 148
- Frezowanie: Glory
- Uchwyt Cosma M 12749.320 Nikiel matowy /art. 21844
- Uchwyt Cosma M 12748.160 Nikiel wstawowy /art. 21842
- Blat: Arkusz akrylowy Getacore GC 4410 Concrete Riva
- Panel ścienny: MDF Fenix NTM Bloom 0771 / Fenix NTM Bloom 0771 19 mm /art. 115723

Bel **Viso**[®]

FREZOWANIE GLORY



RAL 9005



RAL 7037



RAL 7012



RAL 7040



RAL 1019



WCP 127

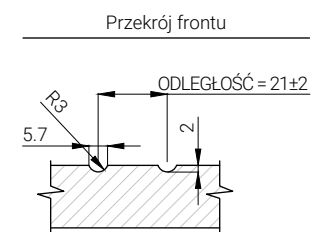
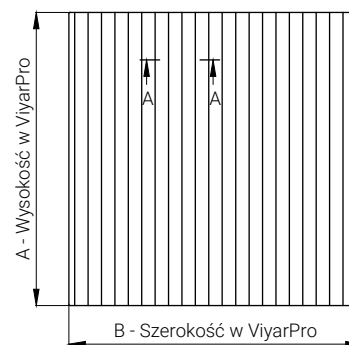

FRONTY LAKIEROWANE

MATERIAŁY UŻYTE W WIZUALIZACJI:

- Kolor: NCS S 0804Y30R
- Frezowanie: Grace
- Profil GOLA poziomy Ferro Fiori L = 4100 mm, typ L nikiel brush /art. 72558
- GOLA profil poziomy Ferro Fiori z rowkiem do LED, L = 4100 mm, Typ C, nikiel brush /art. 117884
- Blat: MDF Arpa 3447 Ker 19 mm /art. 111176
- Panel ścienny: MDF Arpa 3447 Ker 10 mm /art. 84210

Bel **Viso**[®]

FREZOWANIE GRACE



WCP 176



WCP 83



NCS S 2005Y50R



RAL 7016



RAL 7044



NCS S 1000N

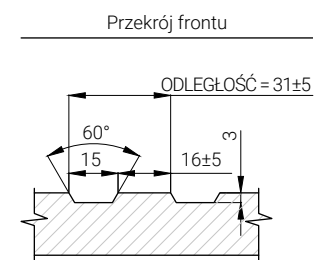
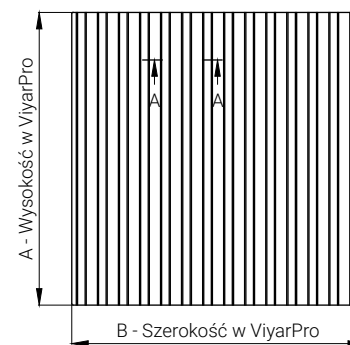



FRONTY LAKIEROWANE

MATERIAŁY UŻYTE W WIZUALIZACJI:

- Kolor: RAL 7031 niebiesko-szary
- Frezowanie: Country
- Uchwyt Marella M 15244.320 nikiel /art. 34617
- Blat Kronospan 4298 UE Atelier Jasny 38 mm /art. 152871
- Panel ścienny: Płyta wiórowa Kronospan 4298 SU Atelier Jasny 18 mm /art. 28717

Bel Viso[®]

FREZOWANIE COUNTRY



NCS S 0300N



NCS S 0500N



RAL 1000



RAL 7046



RAL 7043



RAL 6005

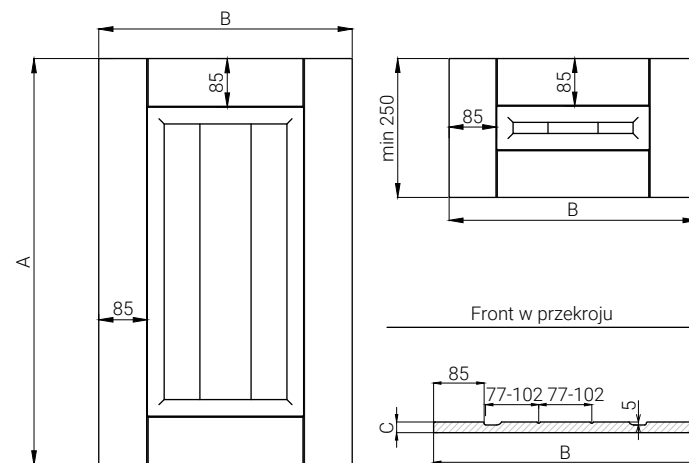

FRONTY LAKIEROWANE

MATERIAŁY UŻYTE W WIZUALIZACJI:

- Kolor: RAL 9003 Biały sygnałowy
- Frezowanie: Klasyczne
- Uchwyt Ferro Fiori D 4440.160 antyczne srebro /art. 115334
- Uchwyt Ferro Fiori D 4440.224 antyczne srebro /art. 115337
- Blat: Arkusz akrylowy Getacore GC 2252 Frosted Carat

Bel **Viso**[®]

FRONTY LAKIEROWANE

MATERIAŁY UŻYTE W WIZUALIZACJI:

- Kolor: NCS S 7000N
- Frezowanie: Kosta
- Uchwyt Marella CL 15231.160 antyczne srebro /art. 46455
- Blat: Arkusz akrylowy Getacore GC 1472 Miracle Stone

Bel **Viso**[®]



FREZOWANIE KOSTA



NCS S 1002Y50R



WCP 67



RAL 6034



RAL 5023



RAL 5024



RAL 7021

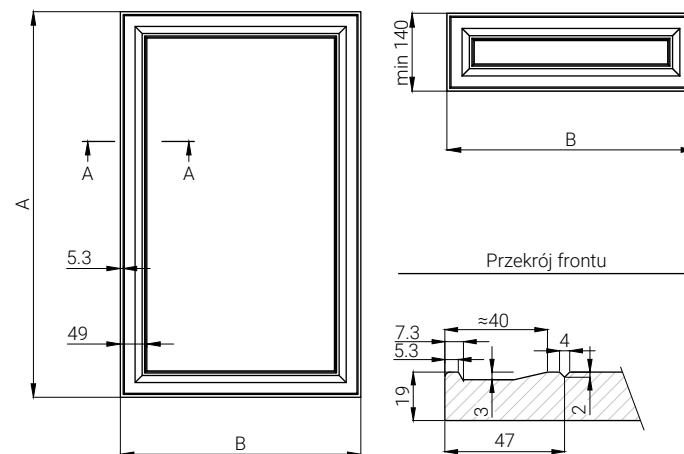



FRONTY LAKIEROWANE

MATERIAŁY UŻYTE W WIZUALIZACJI:

- Kolor: RAL 7024 grafitowy szary
- Frezowanie: Loft
- Uchwyt Ferro Fiori M 0220.192 czarny brush /art. 11482
- Blat Egger H3133 ST12 R3-1U Dąb Davos trufła 38 mm /art. 147934
- Panel ścienny: płyta ścienna z płyty wiórowej 2-stronna Ricci 6019 AR / 6133 AR 14 mm /art. 126888

Bel Viso 

FREZOWANIE LOFT



NCS S 2500N



RAL 7032



NCS S 2005Y60R

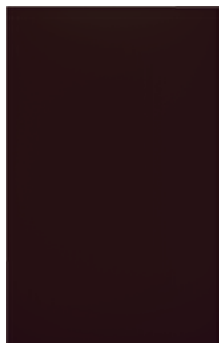

RAL 8017



RAL 6021



RAL 7030

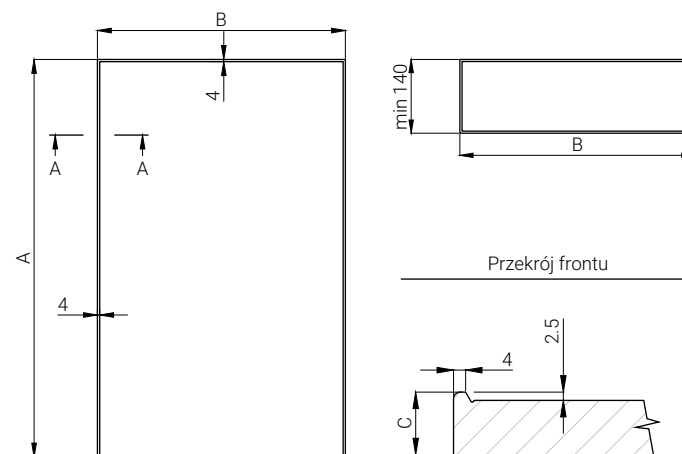

FRONTY LAKIEROWANE

MATERIAŁY UŻYTE W WIZUALIZACJI:

- Kolor: RAL 9023 perła ciemnoszara
- Frezowanie: Maura
- Blat: płyta kompaktowa Fenix NTM 0720 Ingo czarny rdzeń w kolorze 12 mm /art. 94172

Bel Visa[®]

FREZOWANIE MAURA



WCP 25



NCS S 1502Y50R



RAL 1012



WCP 230

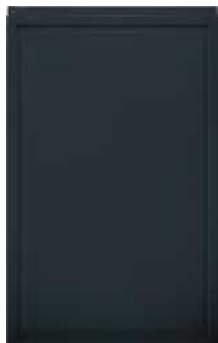

RAL 7031



RAL 6033

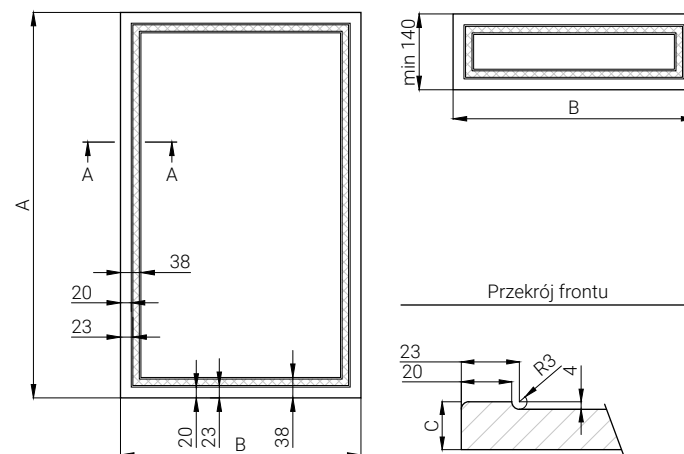

FRONTY LAKIEROWANE

MATERIAŁY UŻYTE W WIZUALIZACJI:

- Kolor: RAL 7044 szary jedwab
- Frezowanie: Nicole
- Uchwyt Marella M 15205.160 nikiel polerowany /art. 46467
- Blat EGGER F205 ST9 R3-1U Grigia Pietra 38 mm /art. 147901

Bel  *Viso*[®]

FREZOWANIE NICOLE

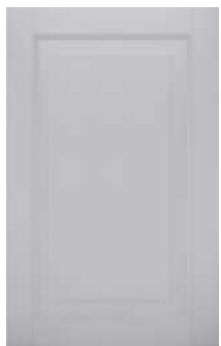

WCP 133



WCP 148



RAL 6019



RAL 1035



NCS S 4005Y50R



RAL 1001

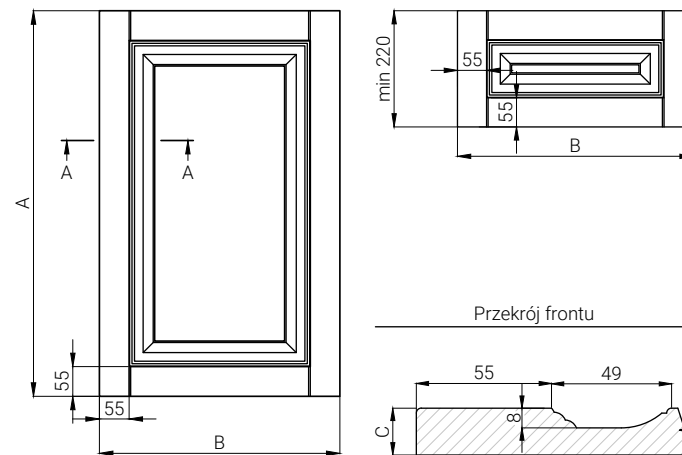

FRONTY LAKIEROWANE

MATERIAŁY UŻYTE W WIZUALIZACJI:

- Kolor: RAL 7030 Kamień szary
- Frezowanie: Paola
- Blat Arpa 3381 LUNA odporny na wilgoć 40 mm /art. 147768
- Panel ścienny: Arpa 3381 LUNA



Bel Viso[®]

FREZOWANIE PAOLA



RAL 9018



RAL 5001



RAL 5009



NCS S 1505Y30R



NCS S 2005Y80R



NCS S 4005Y20R

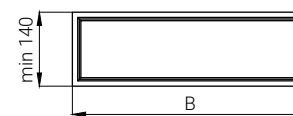
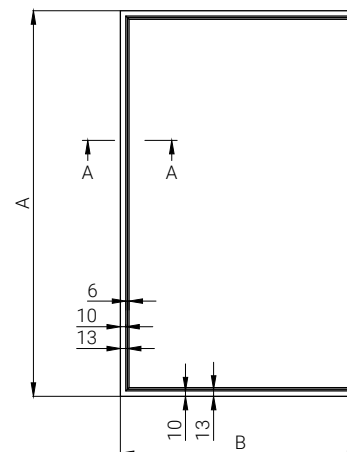

Przekrój frontu

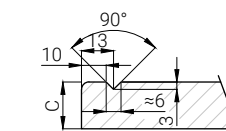

FRONTY LAKIEROWANE

MATERIAŁY UŻYTE W WIZUALIZACJI:

- Kolor: NCS S 7000N, NCS S 1000N
- Frezowanie: Rama
- Uchwyt Marella m 15192.160 Tytan /art. 69679

Bel **Viso**[®]

FREZOWANIE RAMA

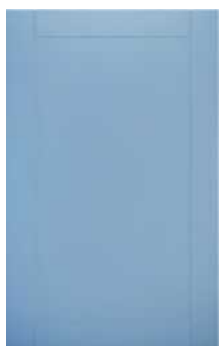

WCP 294



NCS S 3010B30G



NCS S 0804Y30R



RAL 8025



RAL 9011



RAL 7005

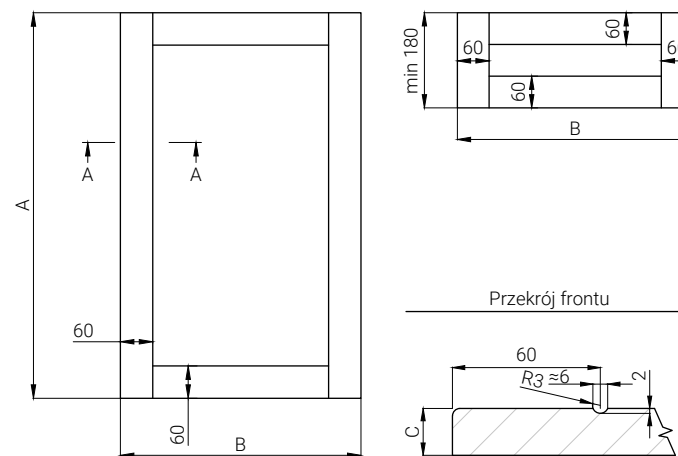



FRONTY LAKIEROWANE

MATERIAŁY UŻYTE W WIZUALIZACJI:

- Kolor: RAL 6021 jasnozielony
- Frezowanie: Sigma
- Uchwyt Marella CL 24228.01.032 czarny matowy /art. 117515

Bel Viso[®]

FREZOWANIE SIGMA



RAL 5020



RAL 5007



RAL 6027



NCS S 7000N



RAL 9023



NCS S 1500N

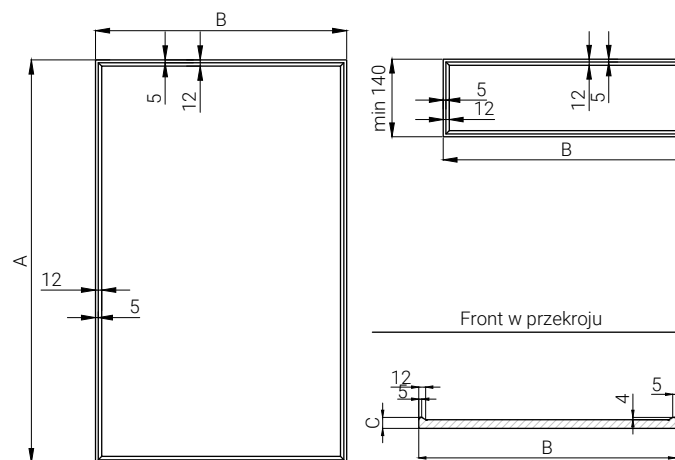

FRONTY LAKIEROWANE

MATERIAŁY UŻYTE W WIZUALIZACJI:

- Kolor: NCS S 1500N
- Frezowanie: Simpl
- Uchwyt Marella M 15191.160 czarny matowy /art. 69671
- Blat Egger F117 / ST76 / R3-1U kamień Ventura czarny 38 mm /art. 147896
- Panel ścienny: Panel Ścienny 2-stronny Egger F117 ST76 / F121 ST87 9,2 mm /art. 148177



Bel Viso[®]

FREZOWANIE SIMPL



RAL 9010



WCP115



NCS S 2005Y40R



RAL 6034



RAL 7004



RAL 1019

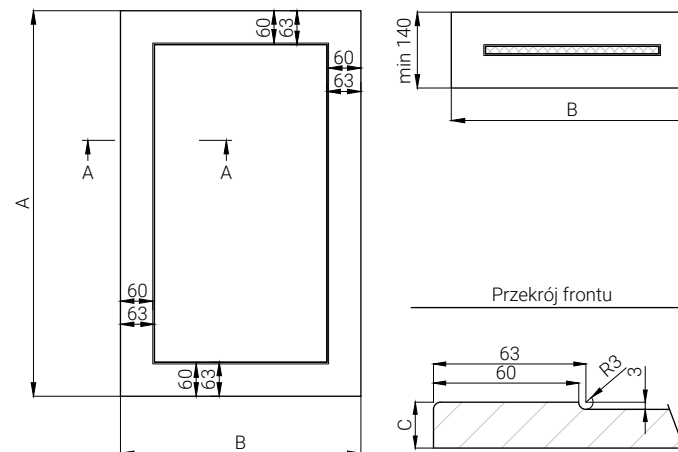



FRONTY LAKIEROWANE

MATERIAŁY UŻYTE W WIZUALIZACJI:

- Kolor: RAL 7042
- Frezowanie: Bez frezowania
- Uchwyt Marella M 15244.320 nikiel ciemny /art. 34619
- Blat Kronospan K095 SU Marmut Terazzo Jasny 38 mm /art. 148264
- Panel ścienny: Skinali (na szkle brylant 6 mm) /art. 49756

Bel Visa[®]

BEZ FREZOWANIA



NCS S 1500N

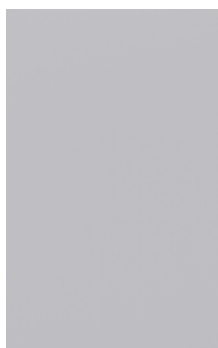

WCP 133

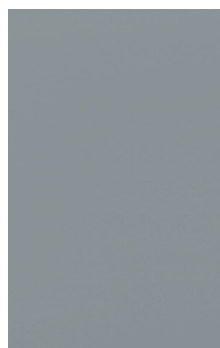

RAL 7042



RAL 7046

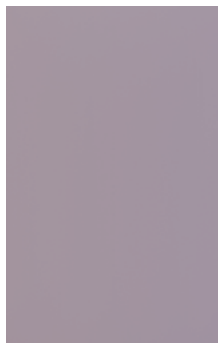

RAL 7036



RAL 7043



FRONTY FOLIOWANE

LIDERZY WSZECHSTRONNOŚCI

Fronty foliowe to wszechstronne i niedrogie rozwiązanie do każdego projektu. Ponad 150 modnych dekorów foliowych – monochromatycznych, błyszczących, matowych, imitacji drewna i metalu i innych materiałów, z frezowaniem i bez.

Fronty foliowane oparte są na austriackiej płycie MDF Egger o dużej gęstości. Do powlekania stosuje się folie PCV niemieckich i włoskich produ-

centów, w szczególności ekskluzywne kolekcje folii Serica i Continental o ulepszonej odporności na uszkodzenia. Aby osiągnąć najwyższą jakość, przed wciśnięciem folii klej nakłada się na całą płaszczyznę i końce frontu.

Fronty foliowane są łatwe w utrzymaniu, mają optymalną odporność na zarysowania, wahania temperatury i barwniki.

Bel *Visa*[®]





USŁUGI DODATKOWE

Frezowany uchwyt 

Witryna (frezowanie na wylot) 

Dwustronna powłoka 

Patyna 

Uchwyt wpuszczany 

Ekspresowa produkcja 

Frezowanie Indywidualne 

FRONTY FOLIOWANE

MATERIAŁY UŻYTE W WIZUALIZACJI:

- Front: folia PCV Kaszmir NL 7393 (SERICA) /art. 49139
 - Frezowanie: Bruno
- Uchwyt Marella M 15187.192 grafit /art. 37297
- Blat: Spiek ceramiczny Neolith Pietra Grey matowy 12 mm /art. 120692
- Panel ścienny: Spiek ceramiczny Neolith Pietra Grey matowy 12 mm /art. 120692



Bel Viso[®]

FREZOWANIE BRUNO



NL 7473 (SERICA)
Lekki szary



NL 7393 (SERICA)
Kaszmir



NL 7455 (SERICA)
Chmury deszczowe



NL 7522 (SERICA)
Lód



VL 4258 (SERICA)
Kombu Green



RL 5989 (SERICA)
Marsala

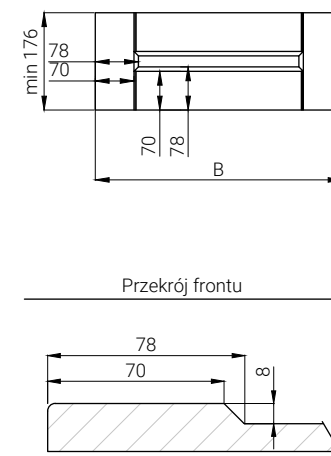
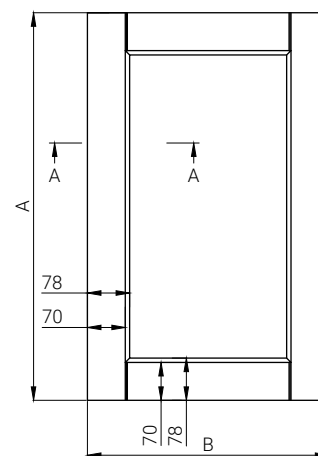
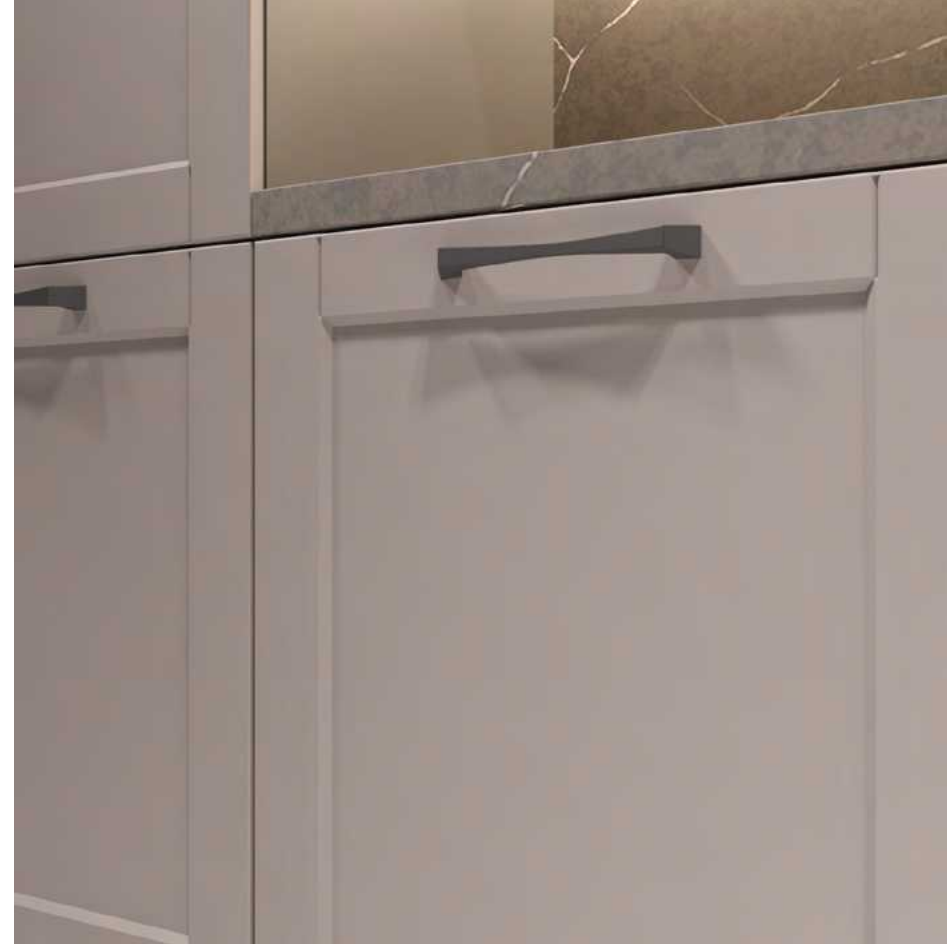

FRONTY FOLIOWANE

MATERIAŁY UŻYTE W WIZUALIZACJI:

- Front: folia PVC Ice NL 7522 (SERICA) /art. 49140
 - Frezowanie: Inel
- Uchwyt Marella M 15205.160 nikiel polerowany /art. 46467
 - Blat: płyta kompaktowa Fenix NTA 5000
Stal Hamilton czarny rdzeń 10 mm /art. 121680



Bel Visa[®]

FREZOWANIE INEL



YEM16-B9
Mussel struktura



VL 4246 (SERICA)
Fiord



NL 7361 (SERICA)
Szary kamień



BL 6221 (SERICA)
Indygo



BL 6230 (SERICA)
Morski niebieski



RL 5983 (SERICA)
Terakota

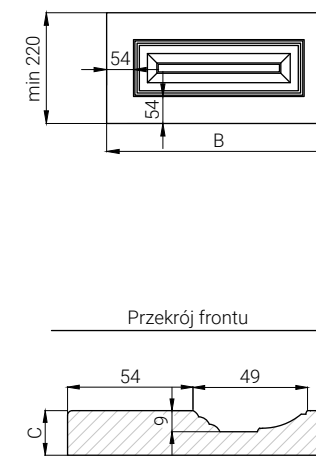
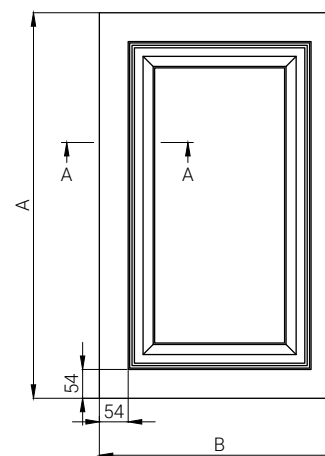

FRONTY FOLIOWANE

MATERIAŁY UŻYTE W WIZUALIZACJI:

- Front: folia PVC deszczowe chmury NL 7455 (SERICA) /art. 49131
 - Frezowanie: Krost
- Profil Gola poziomy, L = 4000 mm, Typ C, Czarny brush, Scilm /art. 58411
- Profil Gola poziomy, L = 4000 mm, typ L, Czarny brush, Scilm /art. 58410
- Blat: płyta kompaktowa Fenix NTM 0720 Ingo czarny rdzeń w kolorze 12 mm /art. 94172
- Panel ścienny: płyta kompaktowa Fenix NTM 0720 Ingo czarny rdzeń w kolorze 12 mm /art. 94172

Bel **Viso**[®]

FREZOWANIE KROST



NL 7522 (SERICA)
Lód



RL 5983 (SERICA)
Terakota



HRB3211UD-B10-0,35
Zielony lód



BL 6230 (SERICA)
Morski niebieski



F4242526
Dąb Ribbeck



NCAB4-B9
Struktura kaszmiru

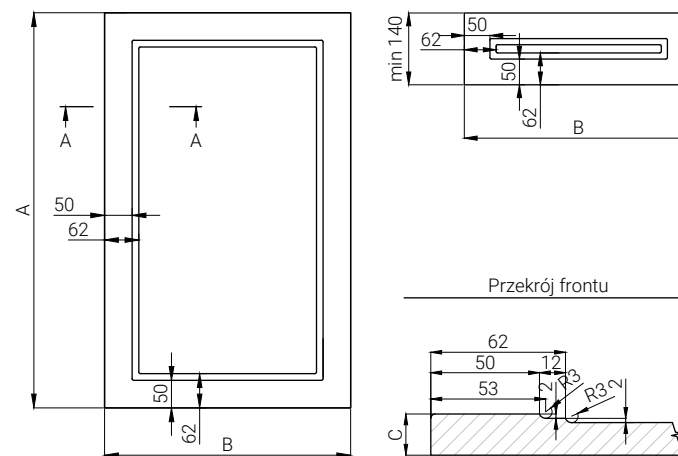



FRONTY FOLIOWANE

MATERIAŁY UŻYTE W WIZUALIZACJI:

- Front: Folia PVC Marine Blue BL 6230 (SERICA) /art. 49134
 - Frezowanie: Modern
- Uchwyt Marella M 15191.160 tytan /art. 69675
- Blat Egger F095/ST87 / R3-1U Marmur Siena szary 38 mm /art. 147894
- Panel ścienny: Panel Ścienny 2-stronny Egger F095 ST87 / F041 ST15 9,2 mm /art. 148175

Bel Viso[®]

FREZOWANIE MODERN



KADR4-B9
Jasnoszara struktura



NCAB5-B9
Szary kamień struktura



F4242301
Sanremo sand



F4242489
Dąb Riviera



F4242499
Dąb Jeden



F4242526
Dąb Ribbeck

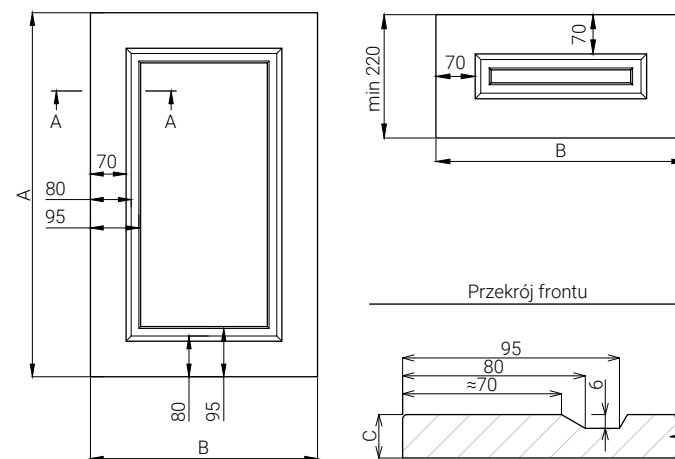

FRONTY FOLIOWANE

MATERIAŁY UŻYTE W WIZUALIZACJI:

- Front: Folia PCV Terakota RL 5983 (SERICA) /art. 68450
 - Frezowanie: Rama z próbą
- Uchwyt VV 323/160, czarny, Turcja /art. 115583
- Blat: płyta kompaktowa Arpa 0509
czarny rdzeń 12 mm /art. 94166

Bel  *Viso*[®]

FREZOWANIE RAMA Z PRÓBĄ

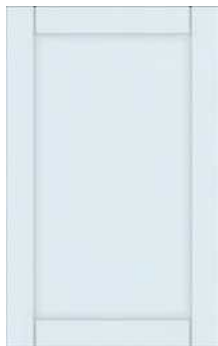

F4275001
Zimny Biały



F4292031
Malowane drewno



D4151-001-M-0,45
Galaktyka Biała



NL 7455 (SERICA)
Chmury deszczowe

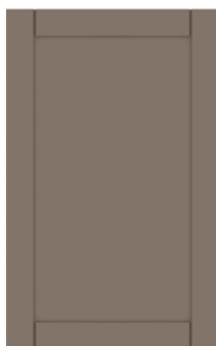

D6326-804-P5
Geraldine



AL 2156 (SERICA)
Pianka

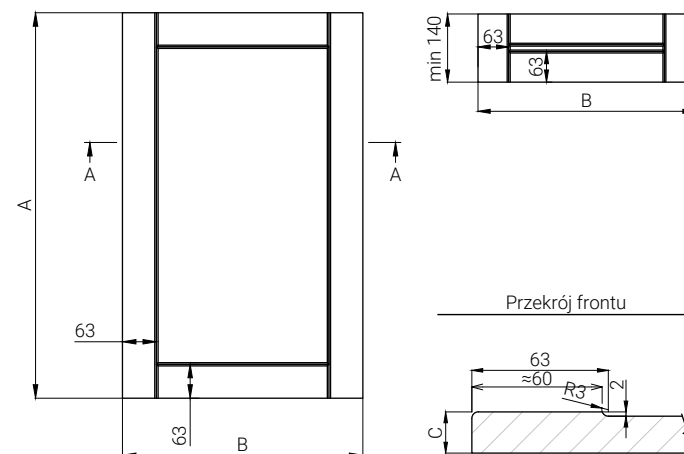



FRONTY FOLIOWANE

MATERIAŁY UŻYTE W WIZUALIZACJI:

- Front: folia PVC fiord VL 4246 (SERICA) /art. 49127
 - Frezowanie: Fresco
- Uchwyt Marella M 15244.320 nikiel /art. 34617
 - Blat: Arpa 3447 Ker 38 mm
 - Panel ścienny: Arpa 3447 Ker

Bel Visa[®]

FREZOWANIE FRESCO



NL 7473 (SERICA)
Lekki szary



NL 7522 (SERICA)
Lód



NL 7455 (SERICA)
Chmury deszczowe



NCAB5-B9
Szary kamień struktura



VL 4246 (SERICA)
Fiord



VL 4258 (SERICA)
Kombu Green

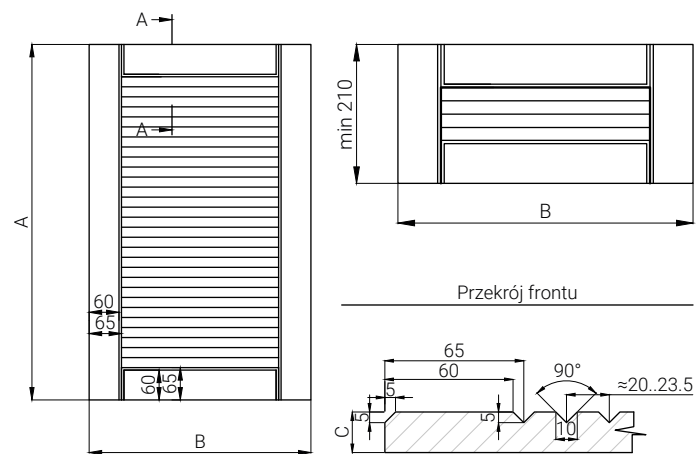

FRONTY FOLIOWANE

MATERIAŁY UŻYTE W WIZUALIZACJI:

- Front: folia PVC Kombu Green VL 4258 (SERICA) /art. 68448
 - Frezowanie: Adel
- Uchwyt Marella M 15191.160 czarny matowy /art. 69671
 - Blat Egger F117 / ST76 / R3-1U kamień Ventura czarny 38 /art. 147896
- Panel ścienny: Panel Ścienny 2-stronny Egger F117 ST76 / F121 ST87 9,2 mm /art. 148177

Bel Viso[®]

FREZOWANIE ADEL



NL 7522 (SERICA)
Lód



BL 6230 (SERICA)
Morski niebieski



VL 4258 (SERICA)
Kombu Green



RL 5983 (SERICA)
Terakota



RL 5989 (SERICA)
Marsala



F4242526
Dąb Ribbeck

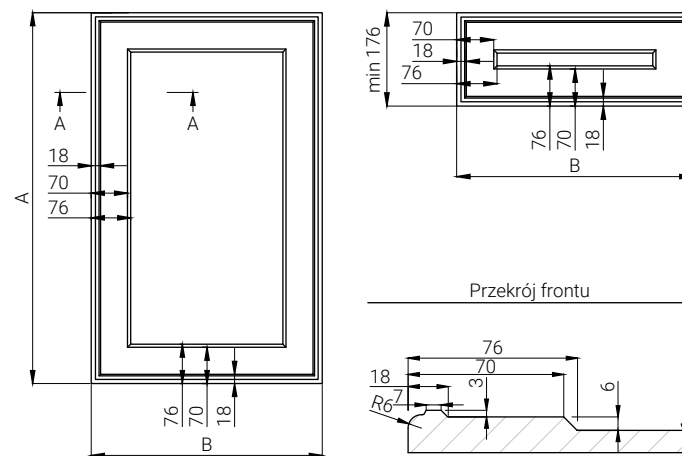



FRONTY FOLIOWANE

MATERIAŁY UŻYTE W WIZUALIZACJI:

- Front: Folia PVC Marine Blue BL 6230 (SERICA) /art. 49134
- Frezowanie: Louis
- Uchwyt Marella CL 24228.01.032 czarny matowy /art. 117515

Bel Viso[®]

FREZOWANIE LOUIS



NL 7393 (SERICA)
Kaszmir



D6326-804-P5
Geraldine



NL 7522 (SERICA)
Lód



VL 4246 (SERICA)
Fiord



NL 7455 (SERICA)
Chmury deszczowe



BL 6221 (SERICA)
Indygo

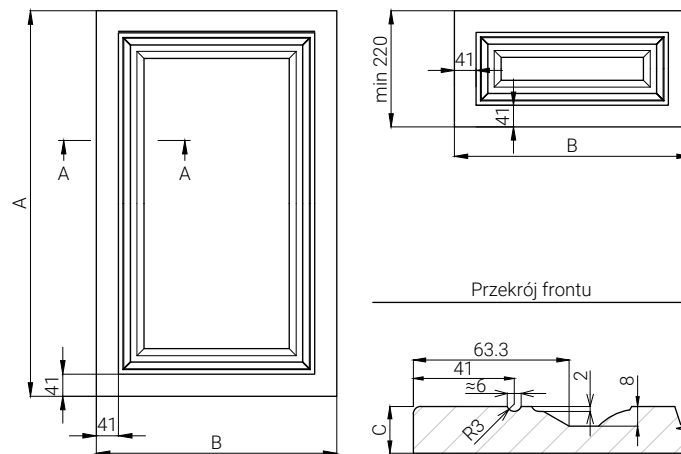

FRONTY FOLIOWANE

MATERIAŁY UŻYTE W WIZUALIZACJI:

- Front: Folia PVC Geraldine D6326-804-P5 /art. 67878
Folia PVC mussel struktura YEM16-B9 /art. 28382
- Frezowanie: Soul
- Uchwyt Marella M 15194.160 grafit /art. 69687
- Uchwyt Marella M 15194.320 grafit /art. 69690

Bel Viso[®]

FREZOWANIE SOUL



D4151-001-M-0,45
Galaktyka Biała



VL 4246 (SERICA)
Fiord



D6326-804-P5
Geraldine



KADR4-B9
Jasnoszara struktura



YEM16-B9
Mussel struktura



VL 4258 (SERICA)
Kombu Green

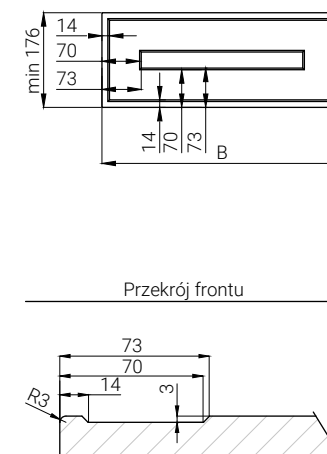
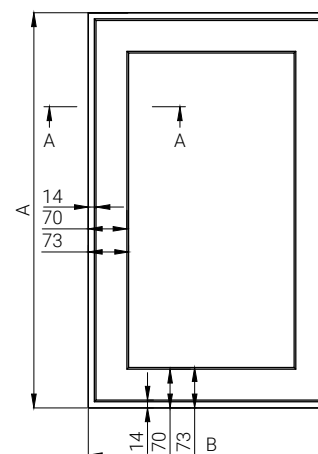

FRONTY FOLIOWANE

MATERIAŁY UŻYTE W WIZUALIZACJI:

- Front: Folia PVC Geraldine D6326-804-P5 /art. 67878
 - Frezowanie: Destiny
- Uchwyt Cosma M 12749.320 Nikiel matowy /art. 21844
- Blat EGGER F205 ST9 R3-1U Grigia Pietra 38 mm /art. 147901

Bel **Viso**[®]

FREZOWANIE DESTINY



RL 5983 (SERICA)
Terakota



BL 6230 (SERICA)
Morski niebieski



F4242499
Dąb Jeden



F4242489
Dąb Riviera



NCAB5-B9
Szary kamień struktura



D6326-804-P5
Geraldine

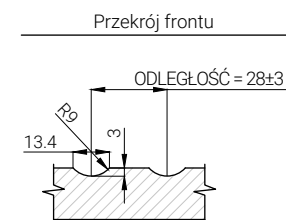
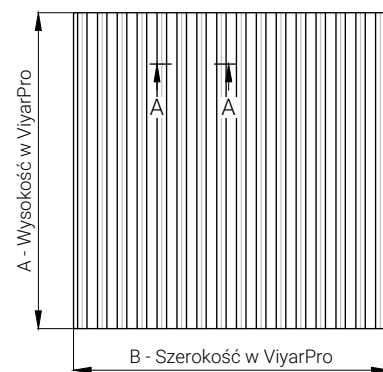

FRONTY FOLIOWANE

MATERIAŁY UŻYTE W WIZUALIZACJI:

- Front: Folia PVC szary kamień struktura NCA B5-B9 /art. 28385
 - Frezowanie: Corrado
 - Uchwyt Marella M 15244.320 nikiel /art. 34617
- Blat Luxeform W015-1 U Czarny 38 mm /art. 149496

Bel **Viso**[®]

FREZOWANIE CORRADO

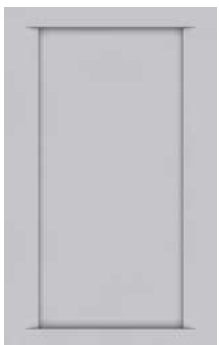

NL 7455 (SERICA)
Chmury deszczowe



VL 4246 (SERICA)
Fiord

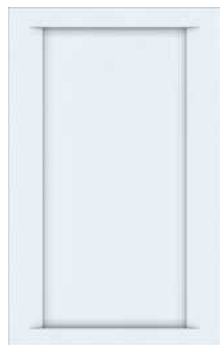

F4275001
Zimny Biały



VL 4258 (SERICA)
Kombu Green



F4242526
Dąb Ribbeck



NL 7522 (SERICA)
Lód

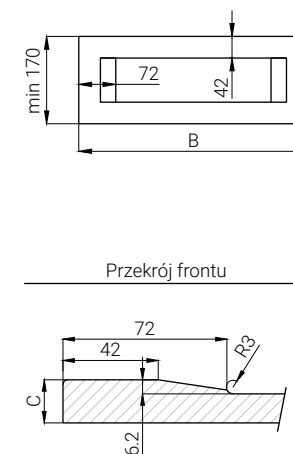
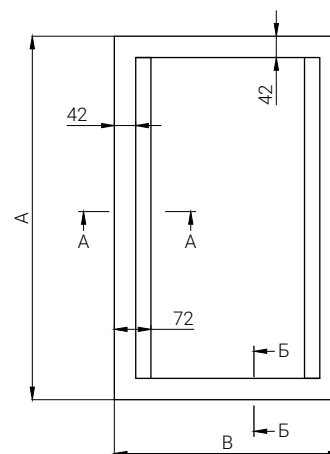

FRONTY FOLIOWANE

MATERIAŁY UŻYTE W WIZUALIZACJI:

- Front: Magnolia połysk YEM-61PG
- Frezowanie: X-Mystic
- Uchwyt Marella M 24232.30 nikiel /art. 69713



Bel Visa 

FREZOWANIE X-MYSTIC

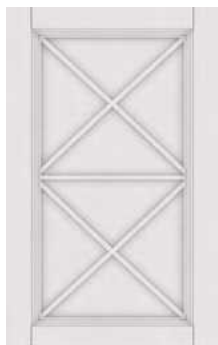

NL 7473 (SERICA)
Lekki szary



VL 4246 (SERICA)
Fiord



BL 6230 (SERICA)
Morski niebieski



YEM16-B9
Mussel struktura



D6326-804-P5
Geraldine



F4242489
Dąb Riviera

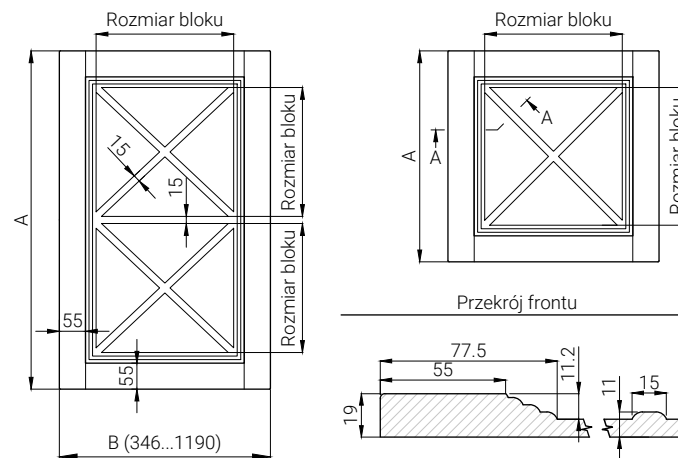

FRONTY FOLIOWANE

MATERIAŁY UŻYTE W WIZUALIZACJI:

- Front: folia PVC Kombu Green VL 4258 (SERICA) /art. 68448
 - Frezowanie: X-Rosso
- Uchwyt Marella M 24232.30 nikiel /art. 69713

Bel Visa[®]

FREZOWANIE X-ROSSO



NL 7522 (SERICA)
Lód



RL 5989 (SERICA)
Marsala



VL 4258 (SERICA)
Kombu Green



F4292031
Malowane drewno



D4151-001-M-0,45
Galaktyka Biała



NCAB4-B9
Struktura kaszmiru

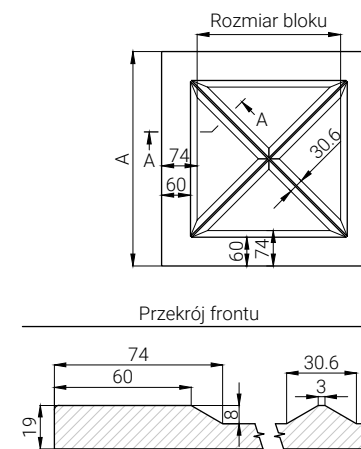
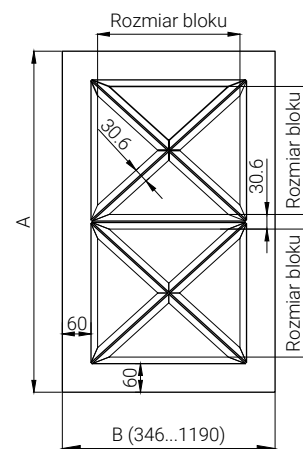

FRONTY FOLIOWANE

MATERIAŁY UŻYTE W WIZUALIZACJI:

- Front: folia PVC Kombu Green VL 4258 (SERICA) /art. 68448
 - Frezowanie: Indywidualne
 - Uchwyt Ferro Fiori M 0030.256, czarny /art. 146949
- Blat EGGER F205 ST9 R3-1U Grigia Pietra 38 mm /art. 147901



Bel Visa[®]

FREZOWANIE INDYWIDUALNE



RL 5983 (SERICA)
Terakota



BL 6221 (SERICA)
Indygo



VL 4258 (SERICA)
Kombu Green



NL 7361 (SERICA)
Szary kamień



VL 4246 (SERICA)
Fiord



NCAB5-B9
Szary kamień struktura



FRONTY HPL I PREFABRYKOWANE FRONTY FUSION

O PODWYŻSZONEJ WYTRZYMAŁOŚCI NA USZKODZENIA

W poszukiwaniu czegoś wyjątkowego zespół Bel Viso stworzył fronty HPL. Są to fronty na bazie płyty MDF, pokryte laminatem wysokociśnieniowym (HPL). W produkcji wykorzystywane są:

- **Fenix** – nanotechnologiczny materiał anti-finger-print o głębokiej powierzchni matowej i zdolności do odzyskiwania kształtu (niweluje rysy).

- **Arpa** – dekoracyjny wielowarstwowy HPL-laminat o wyjątkowej trwałości.

Fronty HPL są praktyczne w użytkowaniu, mają zwiększoną odporność na promieniowanie UV, różne uszkodzenia mechaniczne, wilgoć i barwniki. Teraz w ofercie firmy znajduje się ponad 80 dekorów.



Na zamówienie dostępne są innowacyjne fronty meblowe prefabrykowane FUSION z drewnianym uchwytem.

Na zamówienie dostępne są zaprojektowane przez Viyar, innowacyjne fronty wykonane w technologii: rama dębowa oklejona laminatem HPL i frezowanym na wąskiej krawędzi uchwytem.

Podstawą frontu jest MDF z drewnianą ramą. Przednia i tylna strona frontu pokryta jest nanomateriałem Fenix oraz HPL ARPA. Widoczne połączenie drewna w górnej belce podkreśla naturalność materiału.

Arpa 

FENIX®





USŁUGI DODATKOWE

Laserowe obrzeża 

Dwustronna powłoka 

Uchwyt wpuszczany 

FRONTY

HPL & FUSION

MATERIAŁY DO WIZUALIZACJI:

- Front: Fenix NTM 0718 Londyn Szary
- Blat: płyta akrylowa Getacore GCT 412 Terazzo Artico
- Panel ścienny: płyta ścienna z płyty wiórowej 2-stronna Ricci 6019 AR / 6133 AR 14 mm /art. 126888

FENIX®





FUSION FENIX
NTM 0724
Brom szary



FUSION FENIX
NTM 0750
Komodoro Zielony



FUSION FENIX
NTM 0720
Ingram Czarny



FENIX
NTM 0718
Londyn Szary



FENIX
NTM 0032
Kos Biały



FENIX
NTM 0748
Arizona Beige





FRONTY HPL & FUSION



FENIX
NTM 0751
Dżajpur



FENIX
NTM 0766
Zante Szary



FENIX
BLOOM NTM 0773
Zielony Brak



FENIX
BLOOM NTM 0771
Jasnoniebieski Naxos



FENIX
BLOOM NTM 0772
Żółty Kaszmir



FENIX
BLOOM NTM 0770
Czerwona Askja



FENIX
NTA 5000
Stal Hamilton



FENIX
NTA 5001
Srebrny Dukat



FENIX
NTA 5003
Zloto Cortez



FENIX
NTM 0725
Efez Szary



FENIX
NTM 0029
Mały Biały



FENIX
NTM 0768
Stromboli Szary





FRONTY

HPL & FUSION

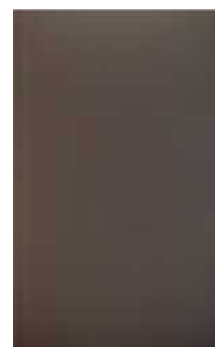

FENIX
NTM 0749
Orinoko Czekolada



FENIX
NTM 0752
Antrim Szary



FENIX
NTM 0719
Luxor Beige



FENIX
NTM 0754
Fez Niebieski



FENIX
NTM 0030
Alaska Biala



FENIX
NTM 0717
Castoro Ottawa



FENIX
NTM 0767
Kolostaj Beżowy



FENIX
NTM 0756
Scari Szary



FENIX
NTM 2628
Doha Cynk



FENIX
NTM 2629
Doha Brąz



FENIX
NTM 2630
Doha Antracyt



FENIX
NTM 2638
Tytan



FRONTY

HPL & FUSION

MATERIAŁY DO WIZUALIZACJI:

- Front: Arpa 0001 Luna, 3276 Luna
- Blat Arpa 0738 Erre 19 mm /art. 111207



Arpa 



FUSION ARPA
0001
Luna



FUSION ARPA
3276
Luna



FUSION ARPA
3408
Losa



ARPA
4587
Aleve



ARPA
3329
Mika



ARPA
3279
Luna





FRONTY

HPL & FUSION



ARPA
3328
Mika



ARPA
4539
Alev



ARPA
4604
Alev



ARPA
3432
Losa

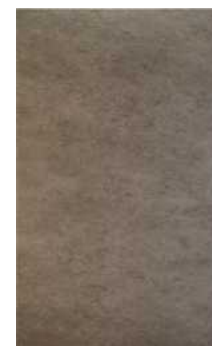

ARPA
3325
Mika



ARPA
3447
Ker



ARPA
4584
Aleve



ARPA
3431
Losa



ARPA
3395
Urban



ARPA
3331
Luna



ARPA
3324
Mika



ARPA
4548
Aleve





FRONTY HPL & FUSION



ARPA
4574
Alev



ARPA
4605
Alev



ARPA
4585
Alev



MDF ARPA
0509
Luna



MDF ARPA
3451
Ker



MDF ARPA
4575
Larix



ARPA
BLOOM 0507
Ker



ARPA
BLOOM 0028
Ker



ARPA
BLOOM 0700
Ker



ARPA
BLOOM 0738
Ker



ARPA
BLOOM 0776
Ker



ARPA
BLOOM 0779
Ker



FRONTY BEL VISO GLASS

WYTRZYMAŁOŚĆ METALU I WARIANTY PRZEZROCZYSTE

Fronty aluminiowe Bel Viso Glass to połączenie solidnej aluminiowej ramy i wypełnienia ze szkła lub lustra. Są szczególnie odporne na wysokie temperatury i wilgoć, a także łatwe w pielęgnacji. Dlatego Bel Viso Glass jest uniwersalne dla wszystkich rozwiązań wewnętrznych.

Na bazie ponad 30 wariantów anodowanych profili aluminiowych z różnymi rodzajami powłok hiszpańskiej marki CORTIZO, chroniących wypełnienie przed uszkodzeniami mechanicznymi.

Elementy frontu montowane są pod kątem 45° i mocowane za pomocą metalowych narożników.

Nieskończona gama wypełnień z nadrukiem UV, matami i kolorowymi foliami pozwala na stworzenie czegoś niepowtarzalnego.

Bel Viso[®]







USŁUGI DODATKOWE

Zastosowanie artystycznego wykończenia 

Lakierowanie RAL 

Uchwyt wpuszczany 

Frezowanie pod zawiasy 



FRONTY BEL VISO GLASS

MATERIAŁY UŻYTE W WIZUALIZACJI:

- Profil aluminiowy R-11 czarny /art. 52004
- Szkło przyciemniane grafit 4 mm /art. 30049
- Uchwyt Ferro Fiori M 0220.192 czarny brush /art. 11482
- Blat Egger H3133 ST12 R3-1U Dąb Davos trufła 38 mm /art. 147934
- Panel ścienny: płyta ścienna z płyty wiórowej 2-stronna Ricci 6019 AR / 6133 AR 14 mm /art. 126888

Bel Viso[®]



R-1 srebro poler.
Lustro brąz
4 mm



R-1 srebro poler.
Lustro brąz
4 mm



R-1 srebro szcztokowany
Szko satyna biały
4 mm



R-1 czarny szcztokowany
Float
4 mm



R-1 czarny szcztokowany
Szko Trix przezroczyte
4 mm



R-1 czarny matowy
Szko Stopsol Classic
grafit 4 mm

R-1

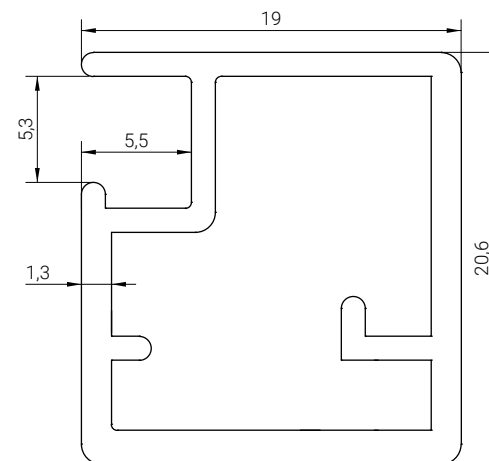



FRONTY BEL VISO GLASS



R-1 srebro poler.
Szkło okienne
przezroczyste 4 mm



R-1 Biały Matowy
Szkło frontowe
Satin biały 4 mm



R-1 Biały Matowy
Szkło Lacobel Pearl
White 1013 4 mm



R-1 brąz matowy
Barwione w masie brąz
4 mm



R-1 brąz matowy
Szkło satyna brąz
4 mm



R-1 Graphite brush poler.
Szkło Stopsol Classic
Clear 4 mm

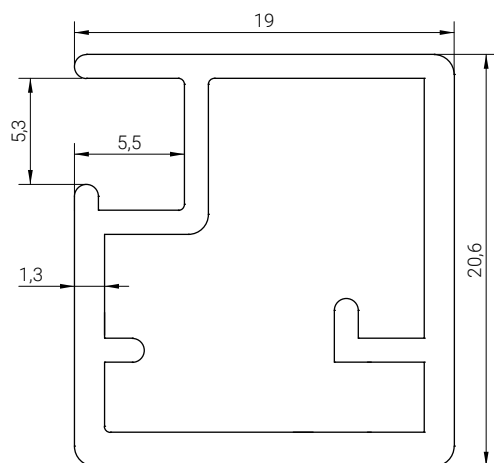

R-1



R-1 złoto poler.
Szkło Planibel Dark Grey
4 mm



R-1 złoto poler.
Szkło Trix przezroczyste
4 mm



R-4 Grafit szcztokowany
Barwione w masie grafit
4 mm



R-1 Szampan
Szkło Master Ligne
Saint Gobain 4 mm



R-1 Nikiel szcztokowany
Szkło Master Thela
Saint Gobain 4 mm



R-4 Grafit szcztokowany
Ekstra biały OptiWhite
4 mm

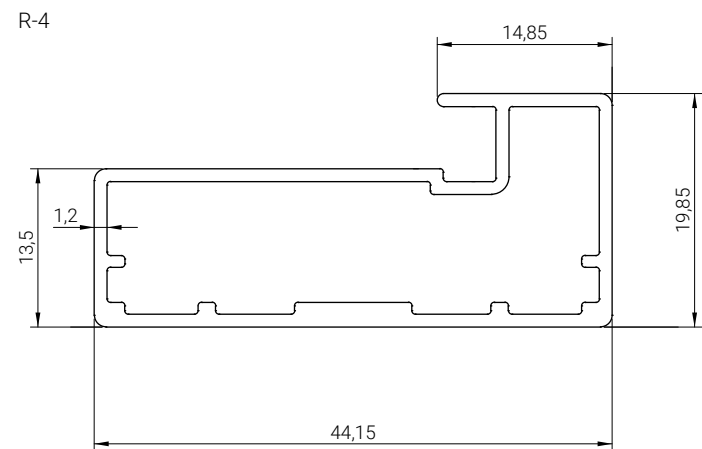

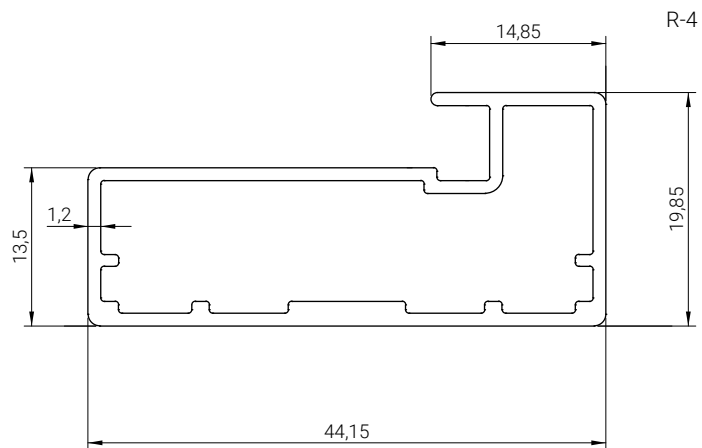

FRONTY BEL VISO GLASS



R-4 srebro matowe
Szkło Trix przezroczyste
4 mm



R-4 Nikiel szczotkowany
Szkło Trix grafit
4 mm



R-4 matowy brąz
Szkło Trix brąz
4 mm



R-4 czarny matowy
Szkło frontowe Flutes
piaskowany 4 mm



R-4 czarny brush poler.
Szkło Stopsol Classic
Brąz 4 mm



R-4 czarny brush poler.
Ekstra biały OptiWhite
4 mm



R-11 Srebrny
Ekstra biały OptiWhite
4 mm, Oracal 076



R-11 Srebro
Lustro Satyn srebrny
4 mm



R-11 Czarny
Lustro MORENA
4 mm



R-11 Czarny
Barwione w masie grafit
4 mm, druk UV



R-11 Czarny
Lustro Grafit satynowy
4 mm



R-11 Srebrny
Szkoło Lacobel Classic
Black 9005 4 mm



R-11

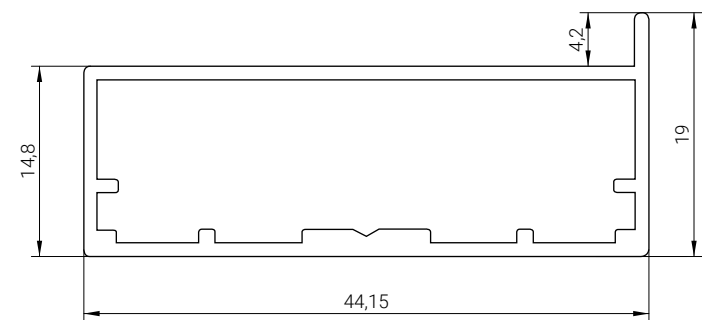



FRONTY BEL VISO GLASS



Noventa grafit szcztokowany
Szkło barwione w masie
grafit 4 mm



Oculito złoto
Lustro Złoto dwustronne
4 mm



Suave biały
Szkło float
4 mm



Noventa czarny matowy
Szkło Planibel Dark Grey
4mm



Oculito + Entero czarny
szcztokowany
Lustro grafitowe 4 mm



Suave brąz matowy
Szkło barwione w masie
grafit 4 mm

110 FRONTY BEL VISO GLASS

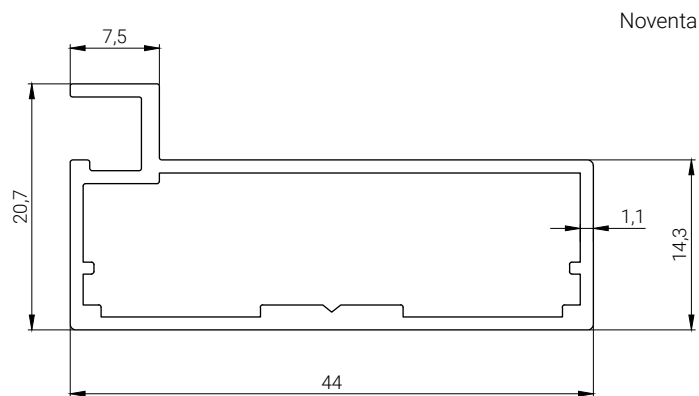

Suave

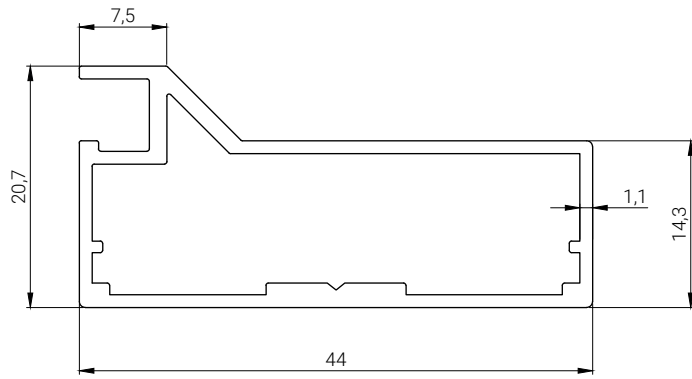

Entero

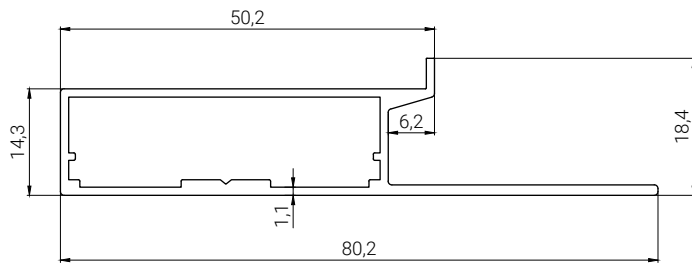

Oculto

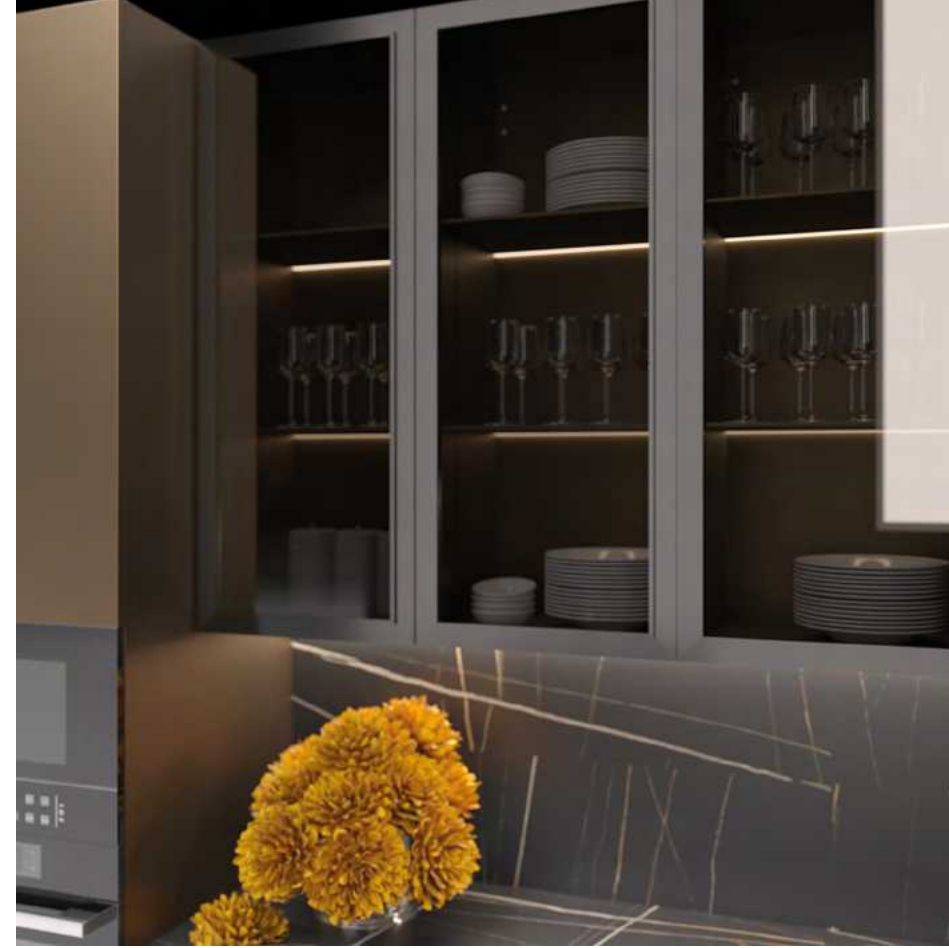
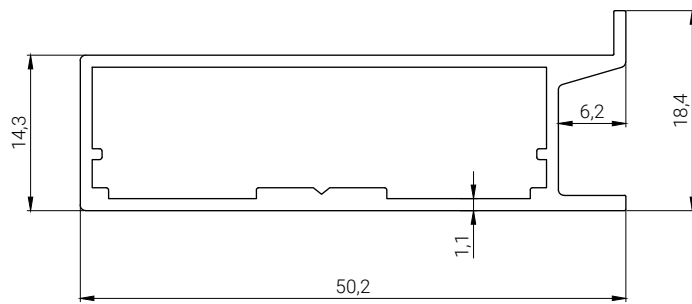

Espada

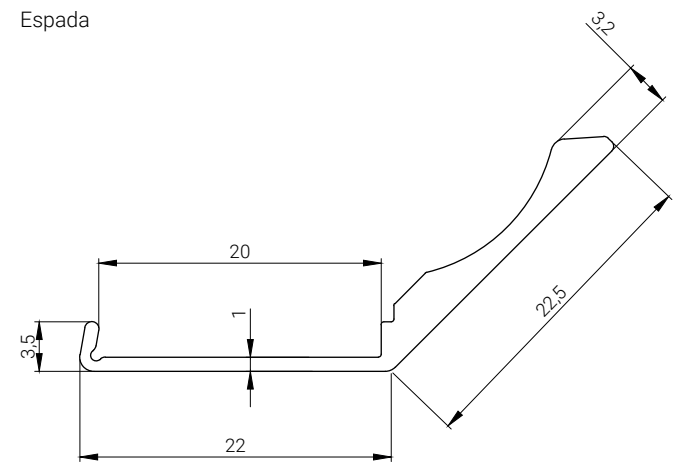



FRONTY BEL VISO GLASS

112 FRONTY BEL VISO GLASS

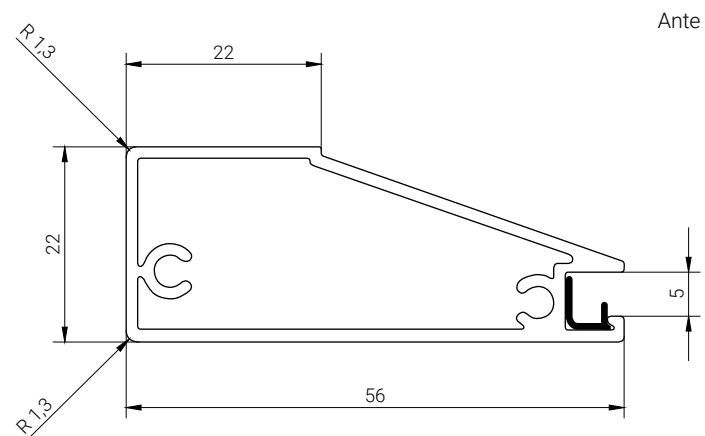

Ante 45°
Szkło Trix brąz
4 mm



Ante 45°
Szkło grafit
4 mm



Ante 45°
Szkło barwione w masie,
tonowane, brąz 4 mm



Ante 90°
Szkło Trix grafit
4 mm



Ante 90°
Szkło Stopsol Classic
grafit 4 mm



Ante 90°
Szkło Stopsol Classic
brązowe 4 mm



Ante Air czarny
Szkło okienne przezroczyste
4 mm



Ante Air czarny
Szkło frontowe Satyn biały
4 mm



Ante Air czarny
Szkło Planibel Dark Grey
4 mm



Ante Air czarny
Szkło Planilaque Ultra white
9003 (Saint-Gobain) 4 mm



Ante Air czarny
Szkło frontowe Matelac
Brown Light 1 236 4 mm



Ante Air czarny
Lustro Srebro
na diamencie 4 mm

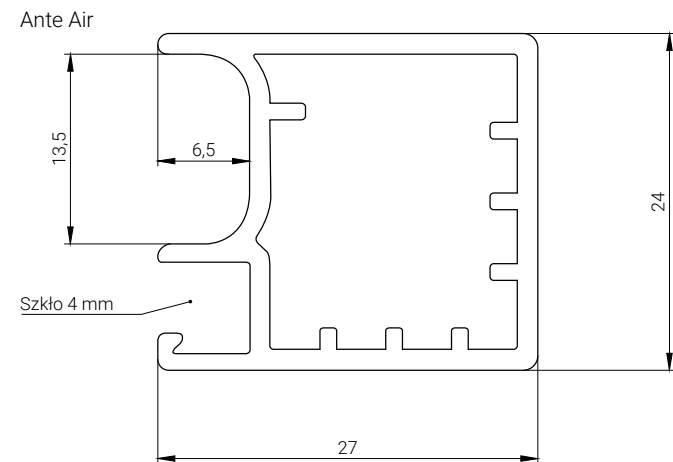

FRONTY AKRYLOWE

WYRAFINOWANIE MA KSZTAŁT

Fronty akrylowe Bel Viso zostały stworzone, aby usatysfakcjonować najbardziej wyrafinowane pomysły w projektowaniu mebli. Posiadają panele z powłoką z laminatu szklanego Rauvisio Crystal firmy Rehau. Materiał ten różni się od innych materiałów – jest wykonany ze szkła, ale jest bardziej stabilny w działaniu.

Zadania dotyczące fazowania wzdłuż obwodu Fasada z efektem 3D.

Łącznie 45 dekorów, w tym lustra, płyty gładkie i dekorowane z matem lub błyszcząca powierzchnia.





USŁUGI DODATKOWE

Laserowe obrzeża 

Uchwyt wpuszczany 

FRONTY AKRYLOWE

MATERIAŁY DO WIZUALIZACJI:

- Front: Panel Rauvisio Crystal V2778 jasny biały połysk /art. 24036
Panel Rauvisio Crystal 1969I Marmur Romano /art. 51548
- Uchwyt Marella M 15194.160 grafit /art. 69687
- Uchwyt Marella M 15194.320 grafit /art. 69690



Rauvisio Crystal
2409L
Atlantico Połysk



Rauvisio Crystal
1969L
Połysk Marmur Romano



Rauvisio Crystal
1721L
Lustrzany



Rauvisio Crystal
V2778
Połysk Jasny biały



Rauvisio Crystal
73703
Połysk Kość słoniowa



Rauvisio Crystal
2109L
Titanio Matowy





FRONTY AKRYLOWE

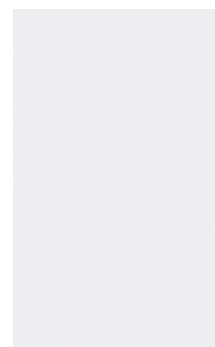

Rauvisio Crystal
2587L
Oro Bianco



Rauvisio Crystal
1700L
Matowy Miętowy

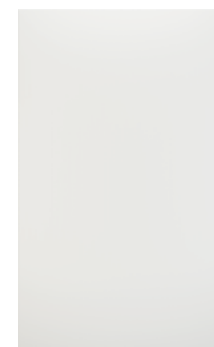

Rauvisio Crystal
1696L
Matowy Jasny biały



Rauvisio Crystal
1687L
Połysk Szary

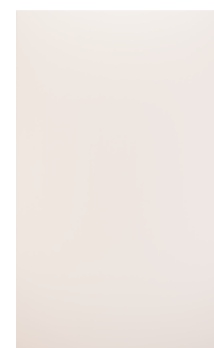

Rauvisio Crystal
1698L
Matowa Kość słoniowa



Rauvisio Crystal
1702L
Matowy Dymny



Rauvisio Crystal
1703L
Matowy Szary



Rauvisio Crystal
1976L
Połysk Bielone Drewno



Rauvisio Crystal
1697L
Biały Matowy



Rauvisio Crystal
1911L
Matowy Jasnoszary



Rauvisio Crystal
1975L
Połysk Drewno Wyżarzane



Rauvisio Crystal
1974L
Połysk Drewno Antyczne





FRONTY AKRYLOWE



Rauvisio Crystal
1971L
Połysk Marmur Czarny



Rauvisio Crystal
2015L
Piano Połysk Czarny



Rauvisio Crystal
1968L
Połysk Marmur Toskania



Rauvisio Crystal
1910L
Połysk Jasnoszary



Rauvisio Crystal
1970L
Połysk Marmur Biały

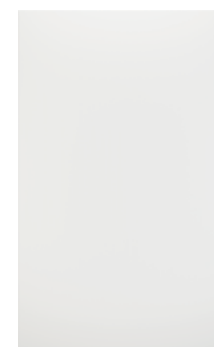

Rauvisio Crystal
V2892
Połysk Biały



Rauvisio Crystal
1684L
Miętowy Połysk



Rauvisio Crystal
2407L
Laguna Połysk



Rauvisio Crystal
1974L
Antyczne drewno



Rauvisio Crystal
2410L
Atlantico Matowy



Rauvisio Crystal
2408L
Laguna Matowa



Rauvisio Crystal
1686L
Dymny Połysk

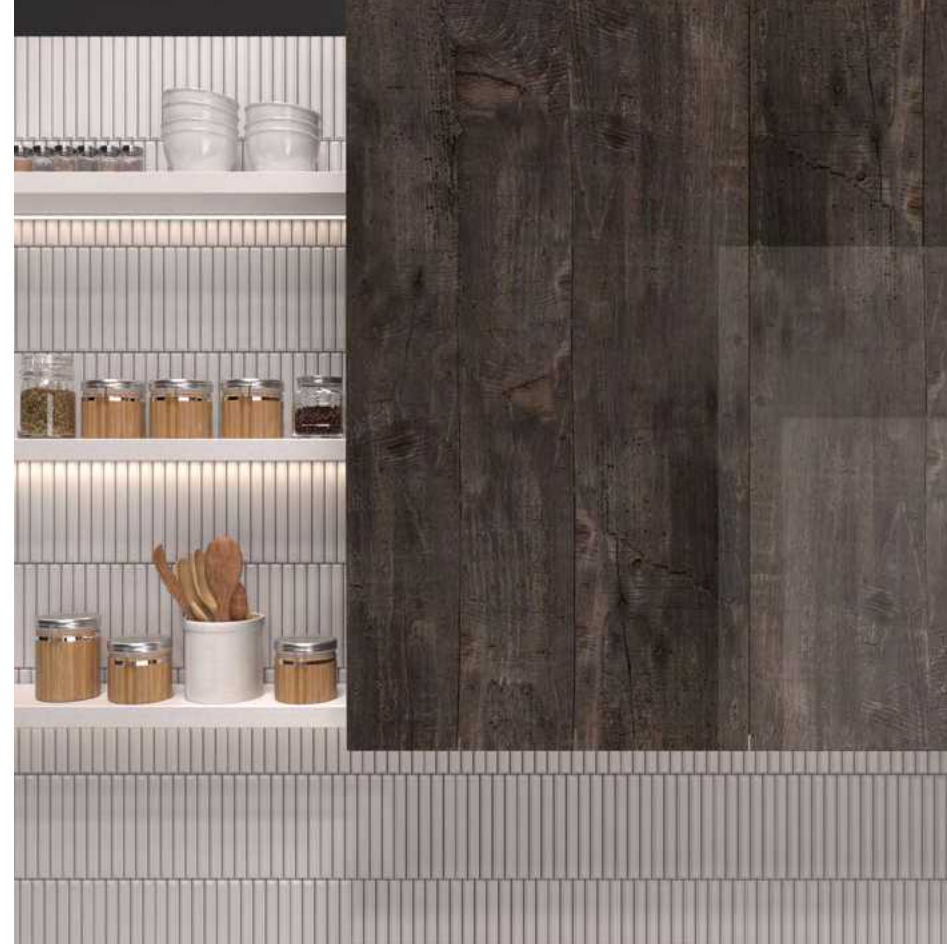

KONTAKT

WIÓR[®]

"WIÓR" Kostro, Romaniuk sp. j

ul.Gen. Wł. Andersa 38

15-113 Białystok

www.wior.pl

tel. 542-020-31-32

Bel Visa[®]



We produce happiness...